

Utjecaj javnog prostora na kreiranje slike grada
scenariji razvoja javnog prostora na primjerima studentskih radova

V.asist.dr.sc. Sanja Gašparović, dipl.ing.arh.

Studenti: **Nina Anić**
Maja Francuz
Slaven Letica
Tina Galešić

Arhitektonski fakultet Sveučilišta u Zagrebu

Af_Katedra za urbanizam, prostorno planiranje i pejzažnu arhitekturu

Preddiplomski studij:

Perivojna arhitektura _ predavanja (4. semestar)

Perivojno oblikovanje _ vježbe (5. semestar)

Pejzažno oblikovanje _ vježbe (6. semestar)

Pejzažno planiranje _ predavanja (6. semestar)

Diplomski studij:

Radionica pejzažne arhitekture _ vježbe (3. semestar)

Suvremena perivojna arhitektura _ predavanja (3. semestar)

Primjena materijala u perivojnoj arhitekturi _ predavanja (3. semestar)

urbani pejsaž



washington dc



450 pariških parkova i vrtova = 30% grada

urbani pejsaž



perivoj maksimir 1794. prvi europski perivoj otvoren za javnost

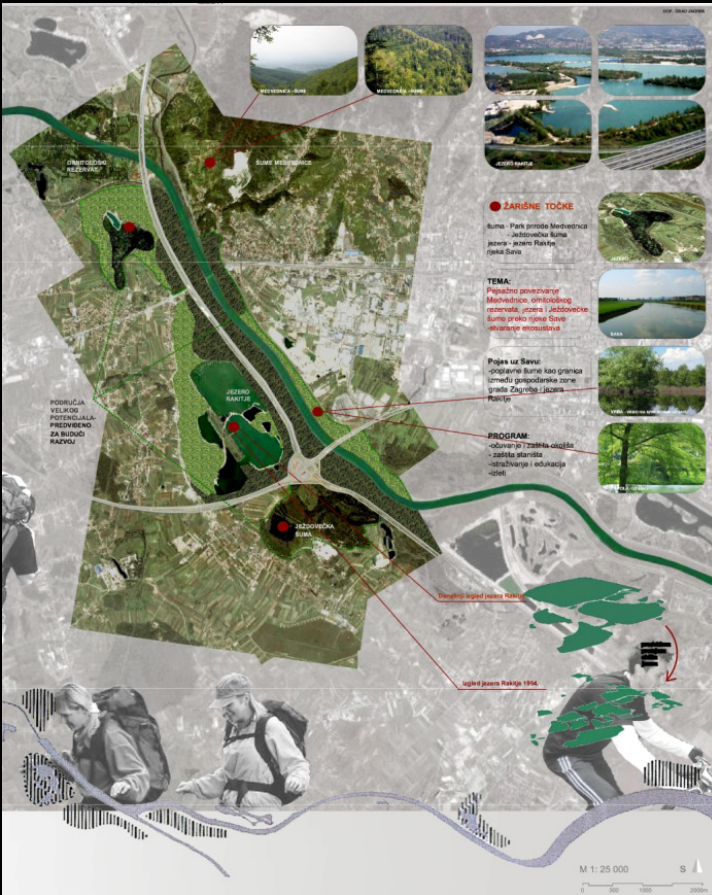
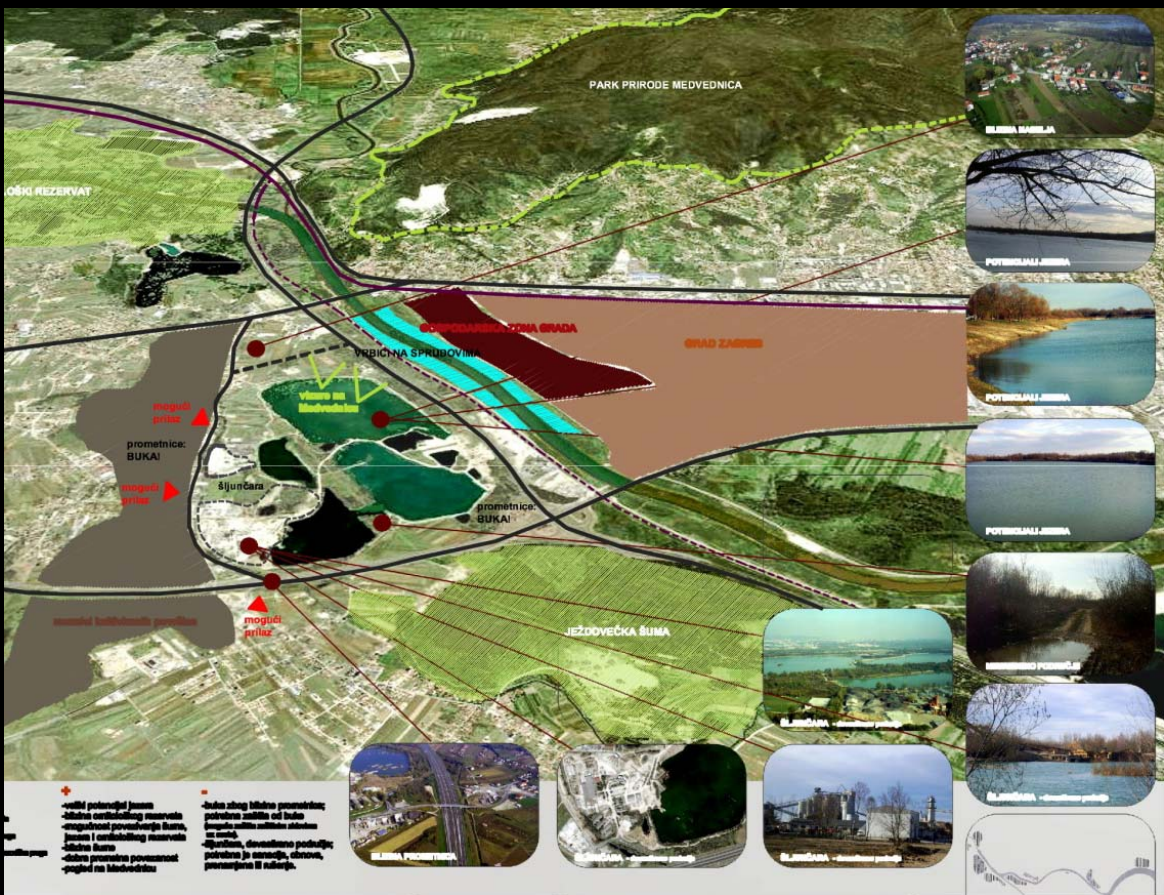

prostorno pejsažna studija _ park rakitje _ zagreb

studentica: biškup vedrana

kolegij **perivojno oblikovanje**



perivoj stambenog naselja

studenti: tina galešić , petra franić

„zeleni“ *mainstream*



greepeace : “gola istina o globalnom zatopljenju” - spencer tunick 2007

landscape urbanism

South East Asia has one of the fastest changing landscapes in the world. What is the impact of this phenomenon to the urban landscape design?

Where does architecture stop and landscape begin? If man and the environment are to co-exist harmoniously, there is a need to understand and be sensitive to the related professions.

The seminar will examine these questions from the South East Asian perspective.

Keynote Address by
Mr Neil Porter &
Mr Andrew Grant

Winners : Singapore Gardens by The Bay International Design Competition

Prof Richard Weller
Professor & Discipline Chair
in Landscape Architecture,
University of Western
Australia, Director Studio
Room 4.1.3

AP Paulo G. Alcazaren
Assistant Professor in
Landscape Architecture,
University of the
Philippines, Director of
PGAA Creative Design

AP Ariya Aruninta
Associate Professor of
Landscape Architecture,
Chulalongkorn University,
Thailand

Mr Henry Steed
Director, ICN Design
International
Singapore

Prof Dr Hadi Susilo Arifin
Professor & Discipline Chair
in Landscape Architecture
Bogor Agricultural
University, Indonesia.

Mr Collin K. Okashimo
Director, Colin K.
Okashimo & Associates,
Singapore

Mr Ng Sek San
Director, Seksan Design,
Kuala Lumpur, Malaysia

Ms Pulphai Kunawat
Associate,
WOHA Designs
Singapore

Landscape Urbanism blurring the lines

Fees : PUBLIC/PROFESSIONALS - \$S20.00
REGISTRATION/ENQUIRY : USHA@sp.edu.sg
Tel: 67721198 Fax: 67721973
Closing date : 7th Feb 2007

Saturday 10th February 2007
9.00am – 5.00pm
Auditorium Singapore Polytechnic



metrograma : PGT plan _ milano

landscape urbanism



le grand paris

urbana preobrazba



odlagalište otpada fresh kills _ staten island _ ny



→

novi gradski park

urbana preobrazba



bivši aerodrom



riemer park _ münchen



urbana preobrazba



napuštena industrija



→

novi zabavni centar ferropolis _ north golpa, d _ 1999

urbana preobrazba



napušteni željeznički kolosijek



high line park _ ny



ovdje / danas?

arhitekt



obilježja javnog prostora



project for public spaces /pps



madrid rio project

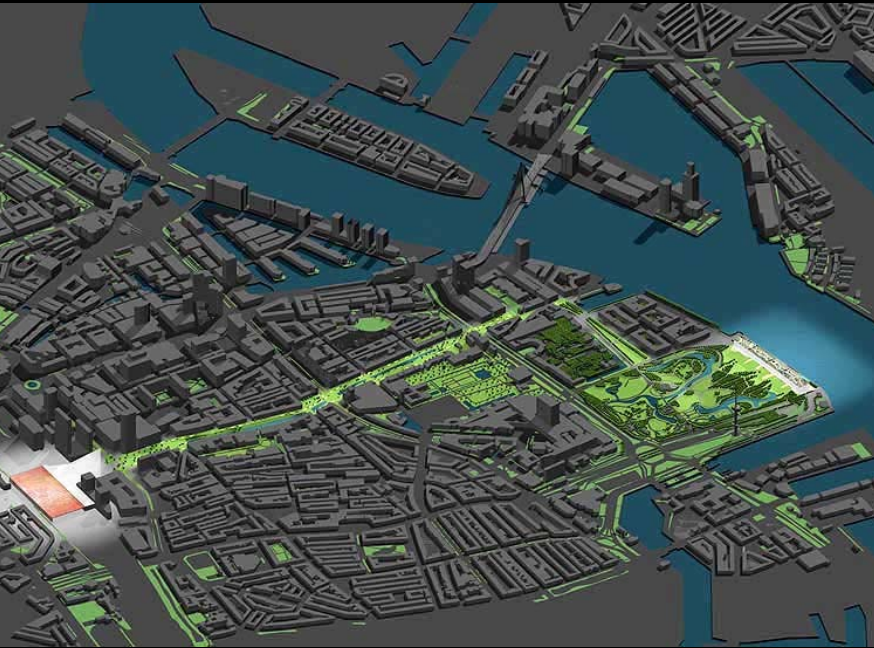

green river rotterdam _ monolab architects _ nl



geelong youth activities area_convic design_australia

tko

? ? ? ?

gdje

? ?

zašto

? ? ?

kada

?

kako

? ?

?

tko ?



tko ?







seascape , thomas wrede _ photo



place de la bourse, bordeaux_f



desierto plaza, baracaldo _es



jardin de la connaissance _ 100landschaftsarchitektur

zašto ?



igralište van campenvaart _carve_hague_nl



garscube landscape link _7n architects

kada ?



gradska plaža _ toronto

kada ?



keelung port _ taivan _ guallart architects

kada ?



elixir _ a luminous potion of water, sound and pixels _ montreal

kako ?



solearena _ lutzow 7 _ essen



paseo altamirano _ marin norero

kako ?



mfo park / switzerland



eusebiushof arnhem _ strootman architects



keelung port _ taivan _ guallart architects

scenariji

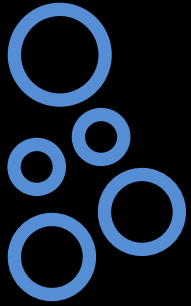

Nina Anić

land art park

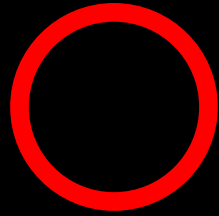

Maja Francuz

dinamična traka

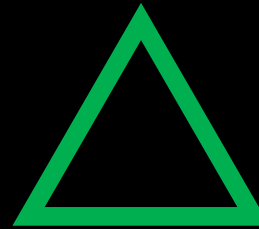

Slaven Letica

green up

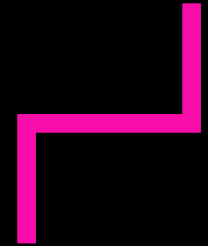

Tina Galešić

pink link

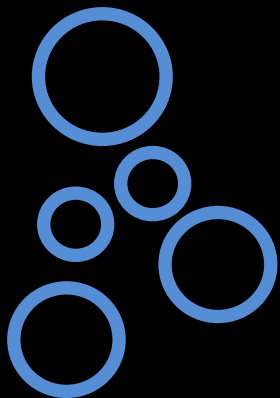

Nina Anić

land art park _ prostorno pejzažna studija _ park rakitje _ zagreb

kolegij: pejzažno oblikovanje _ VI. semestar _ preddiplomski studij

1764.



1902.

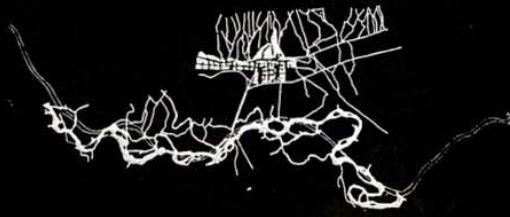

1948



1853./54.

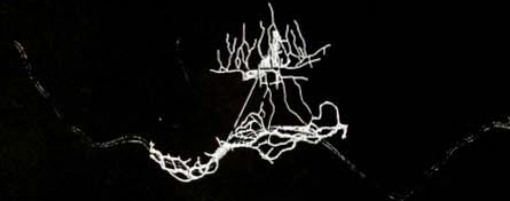

1910



1964

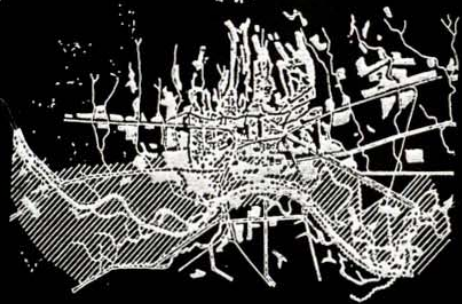

1878.



1931



1997.



ZAGREB I SAVA



crvenimotr3pq.jpg

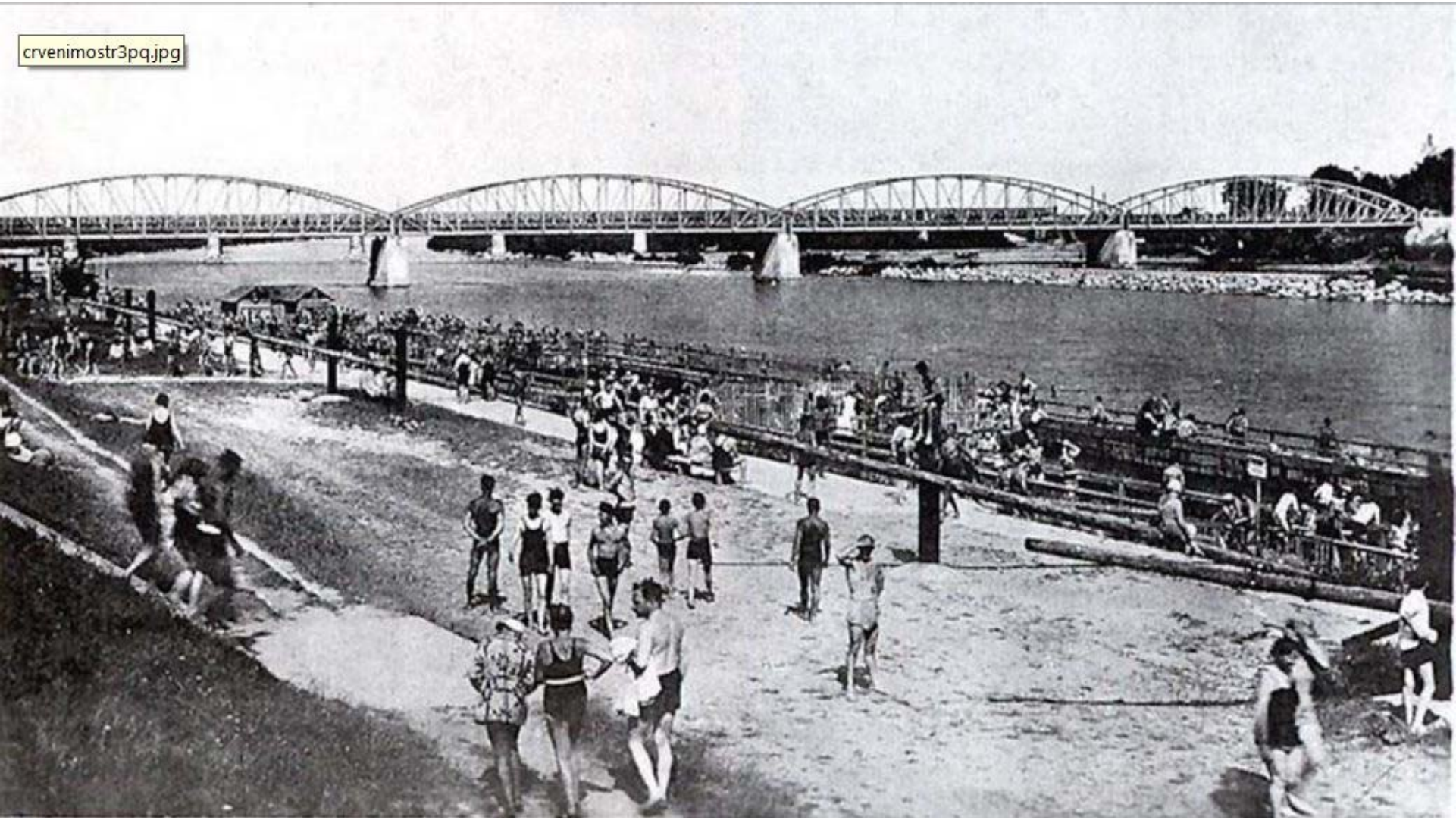

STARO KUPALIŠTE

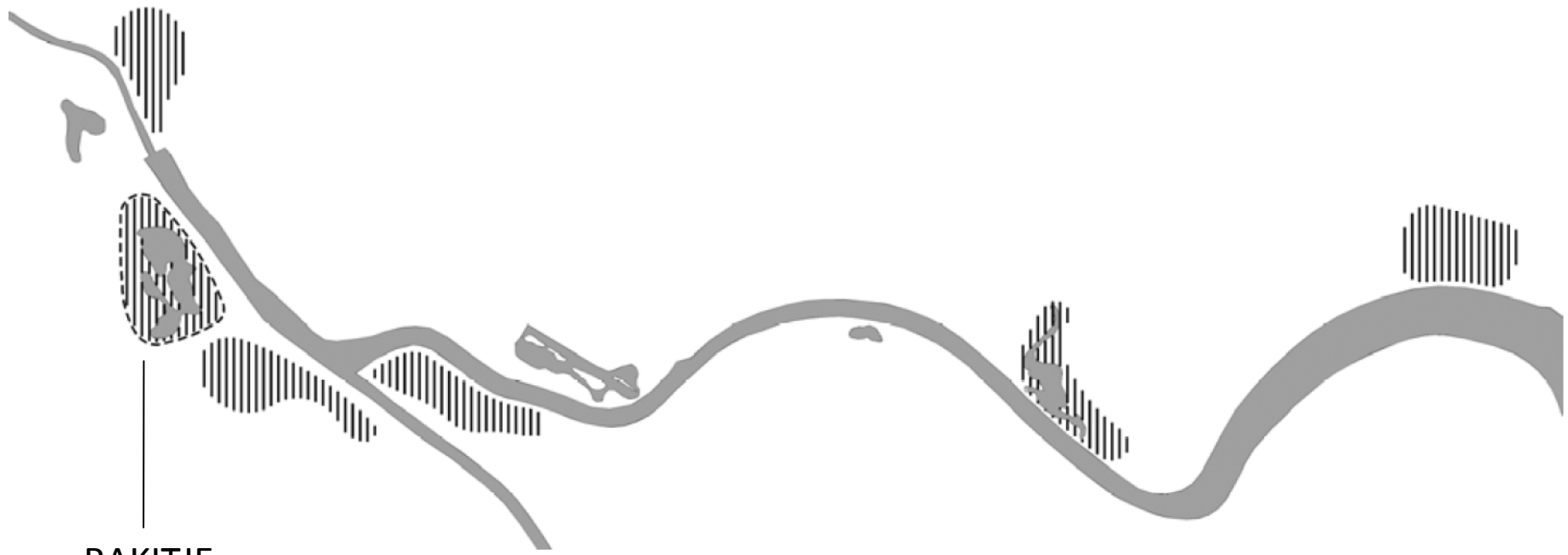

RAKITJE

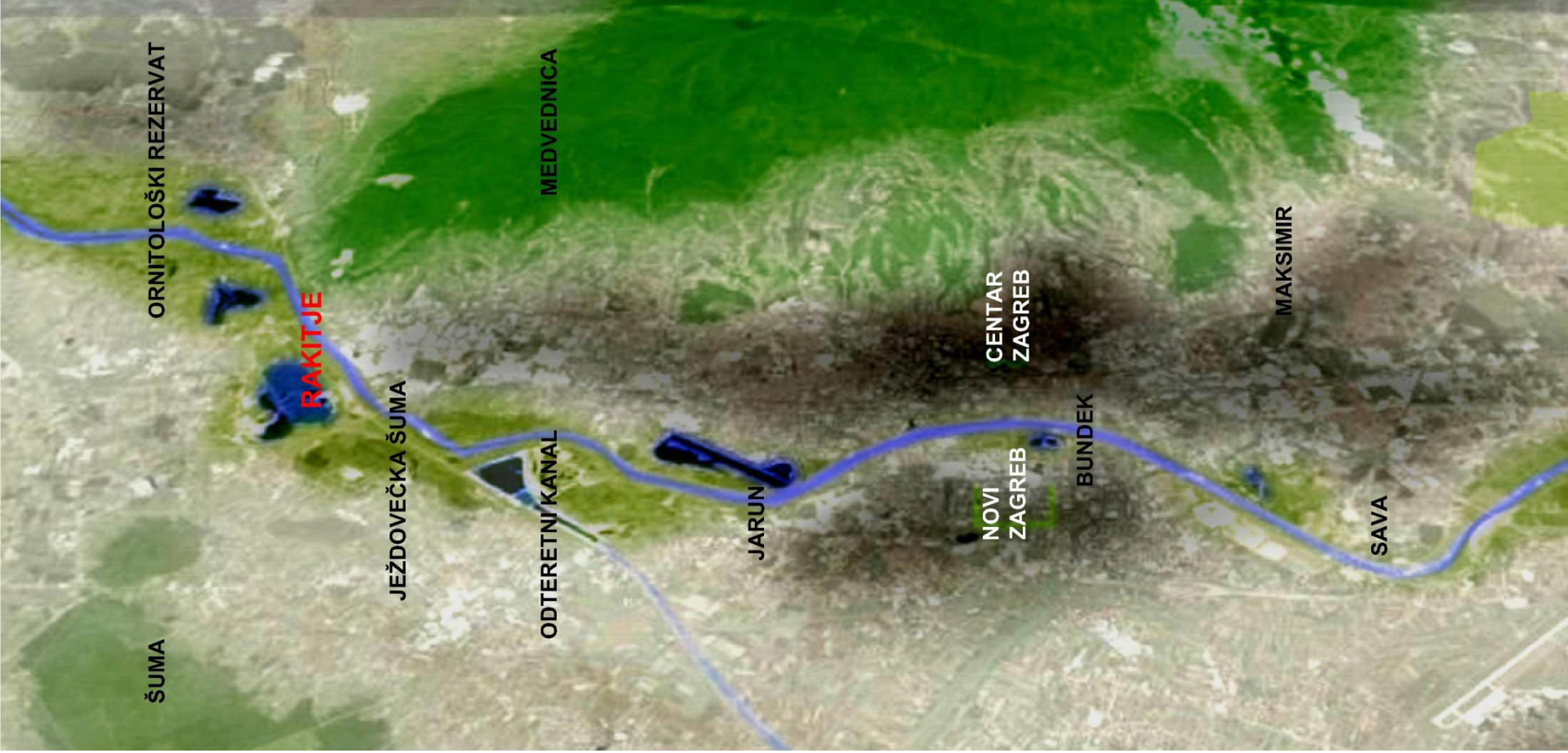

ŠUMA

ORNITOLOŠKI REZERVAT

RAKITJE

JEŽDOVEČKA ŠUMA

ODTRETNI KANAL

MEDVEDNICA

JARUN

NOVI
ZAGREB

CENTAR
ZAGREB

BUNDEK

SAVA

MAKSIMIR

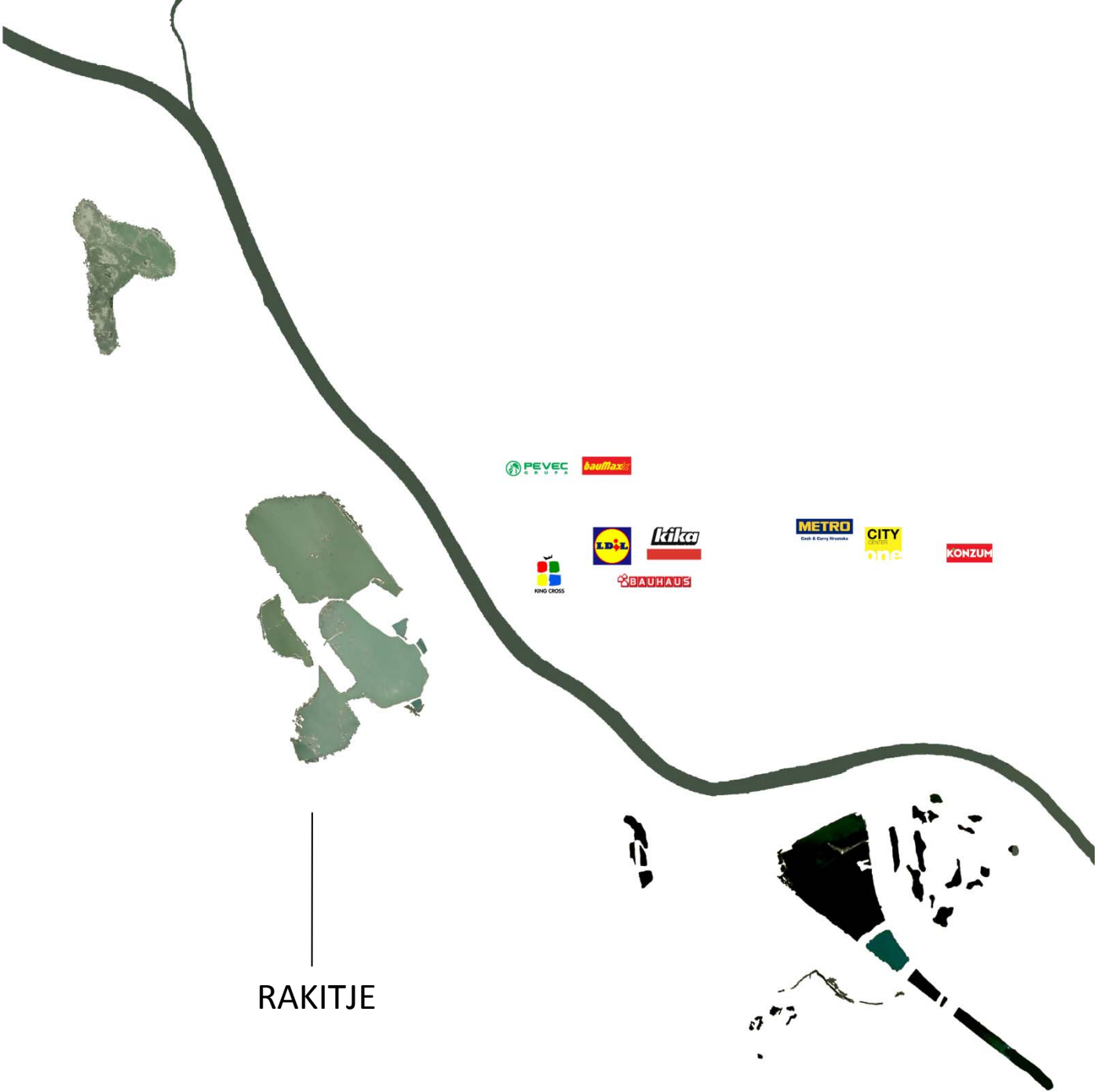

RAKITJE











PRVI DAN OTVORENJA U ARENA CENTRU 100.000 POSJETITELJA



650 m² POVRŠINE TRGOVAČKIH CENTARA NA 1000 STANOVNIKA

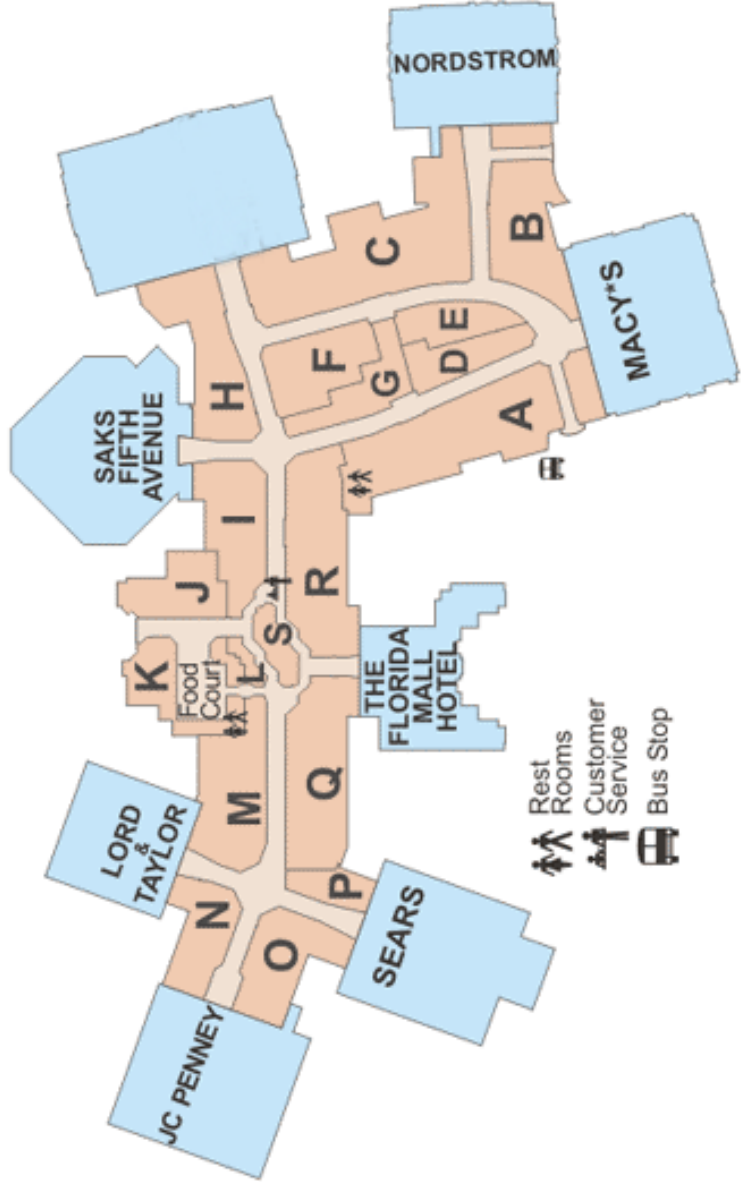

NORDSTROM

MACY'S

SAKS FIFTH AVENUE

THE FLORIDA MALL HOTEL

LORD & TAYLOR

SEARS

JC PENNEY

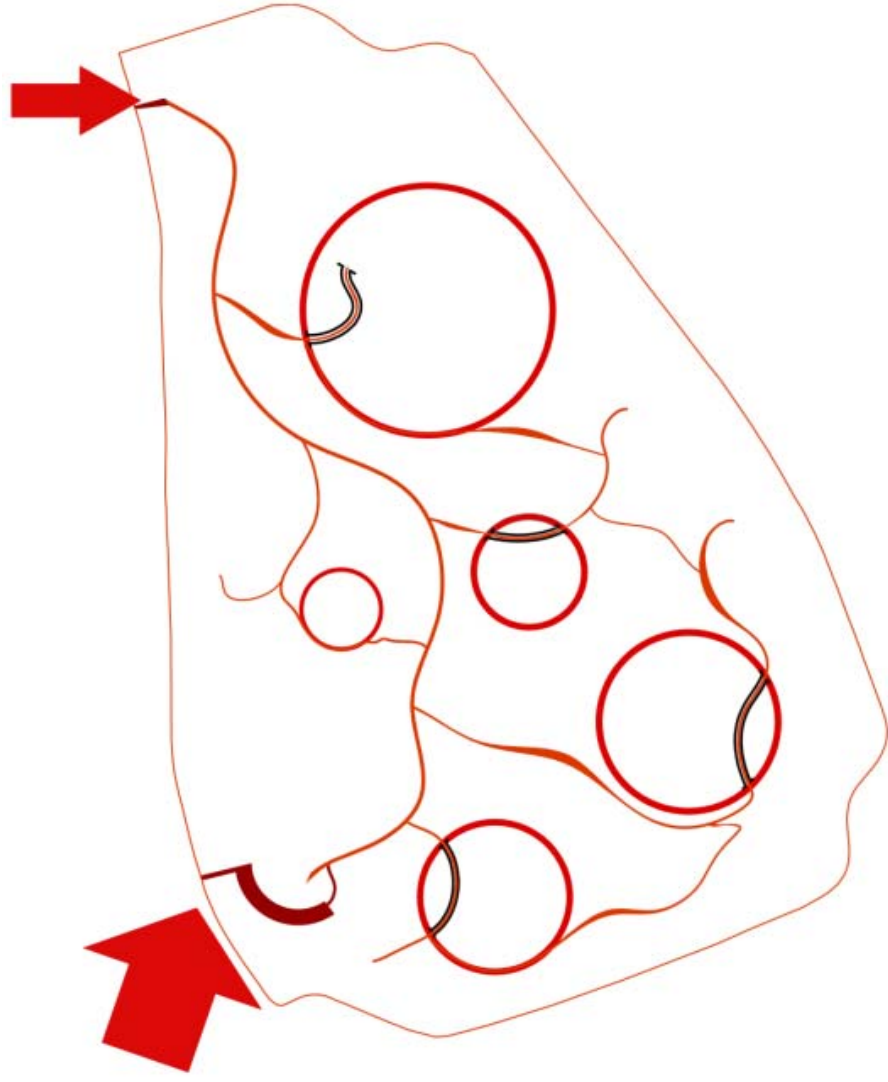

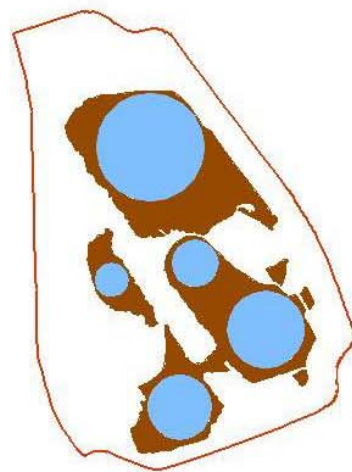
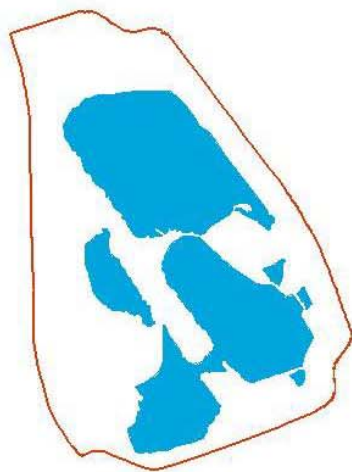
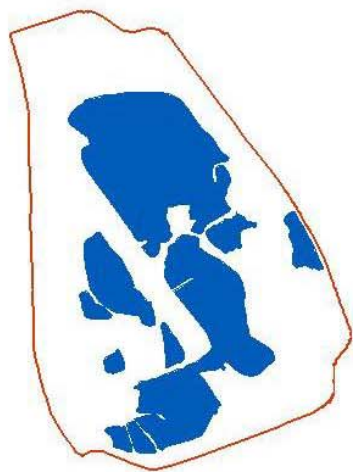

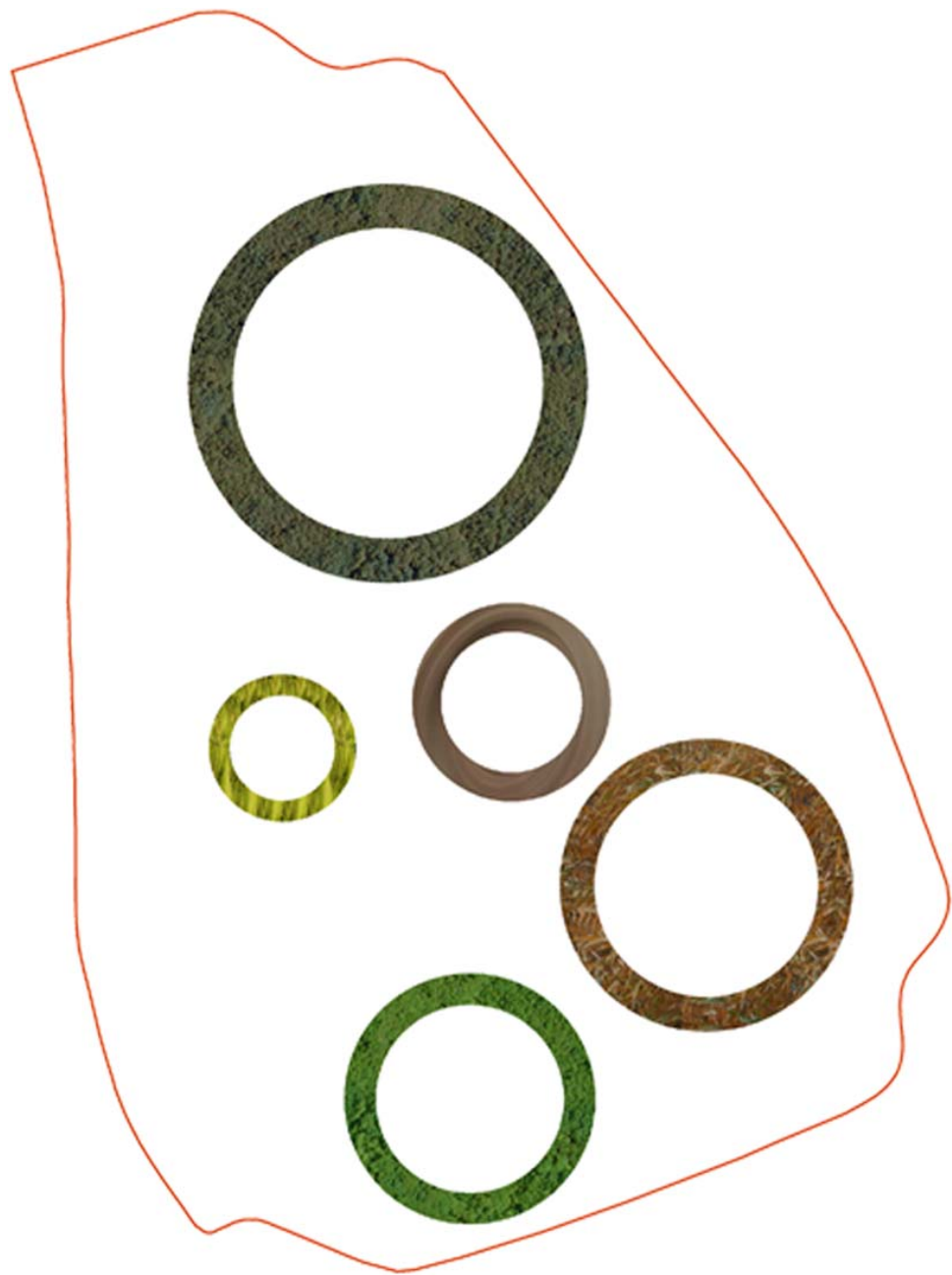

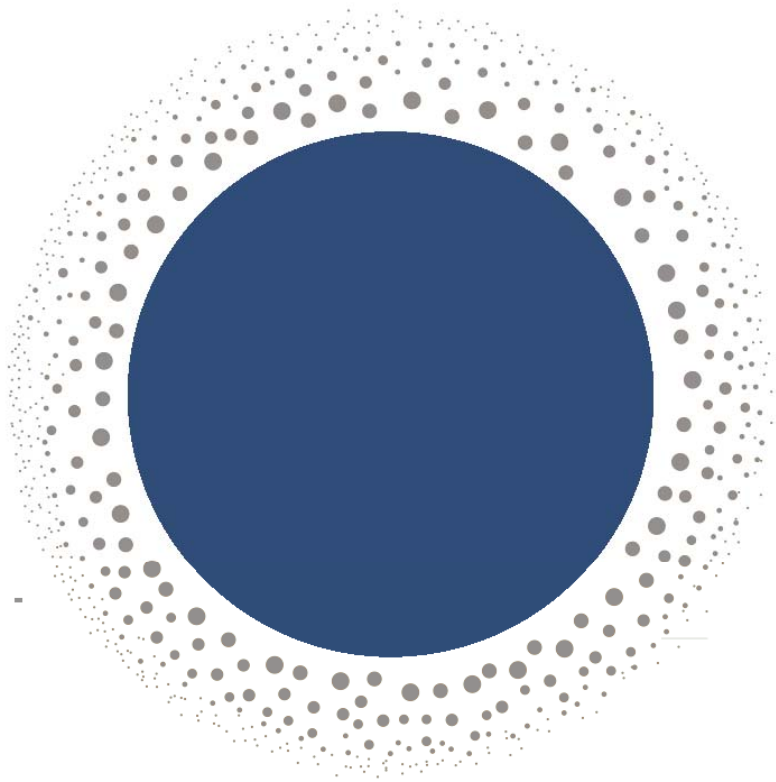



PRESJEK ŠUMA



PRESJEK ŠAŠ



PRESJEK 'KAMENOLOM'

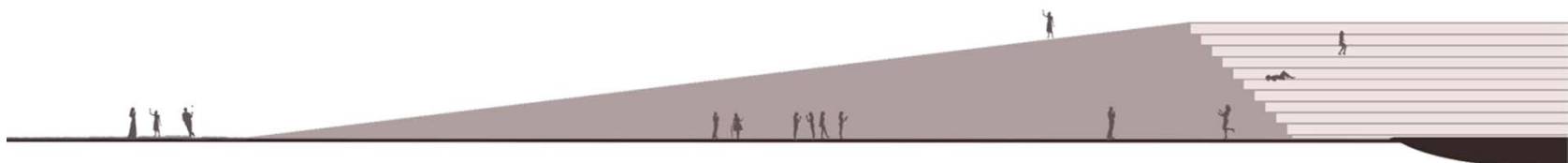

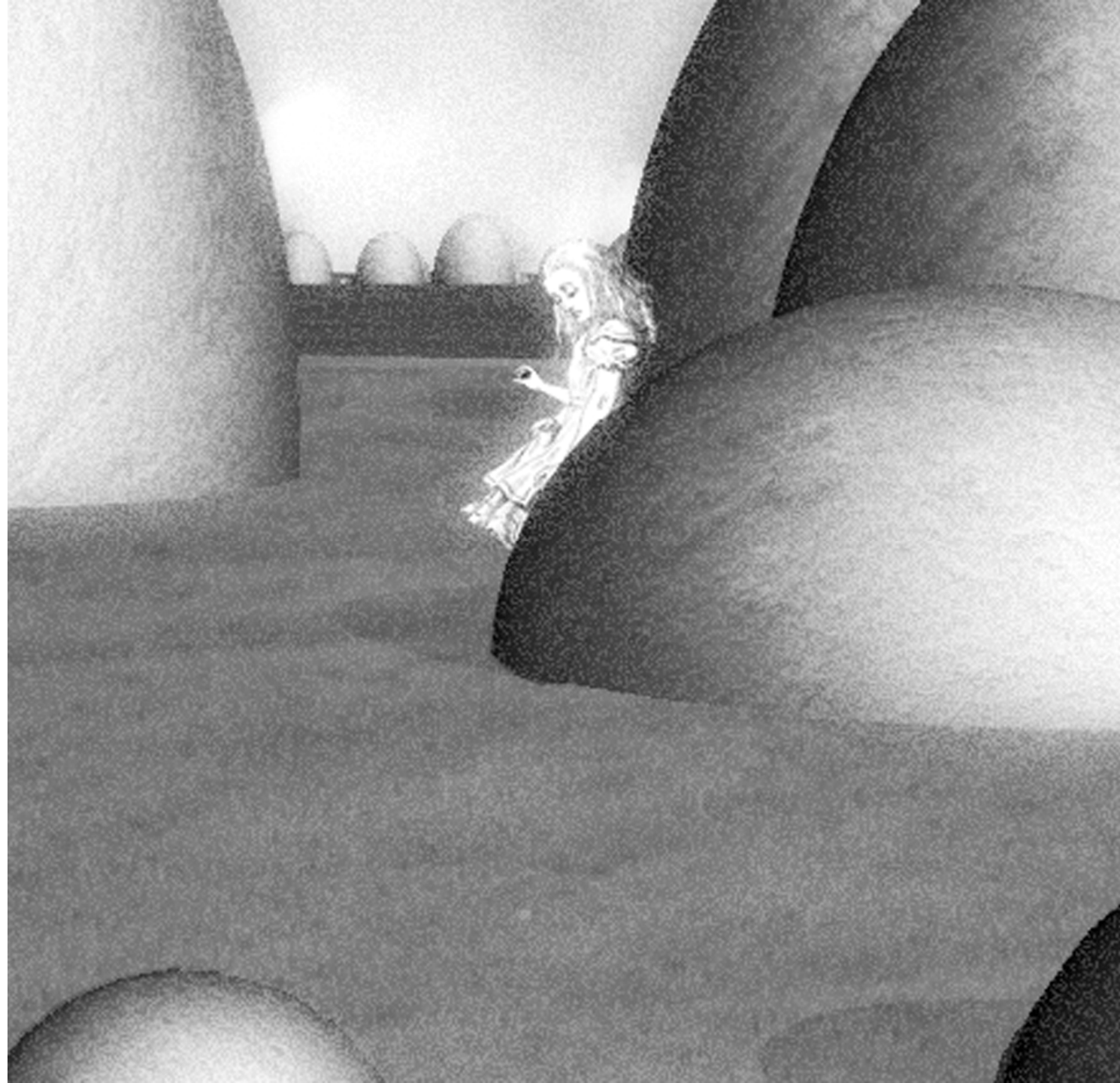



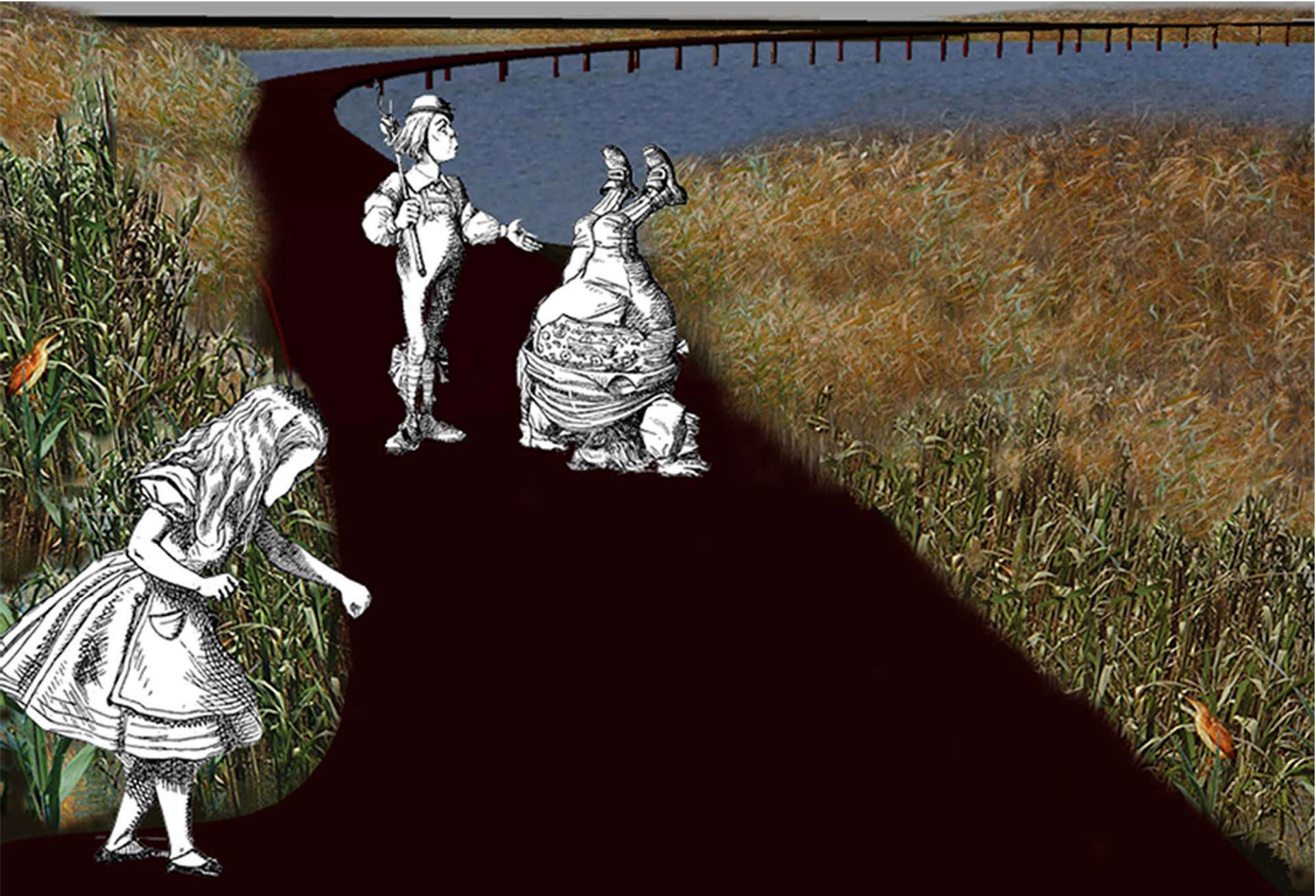

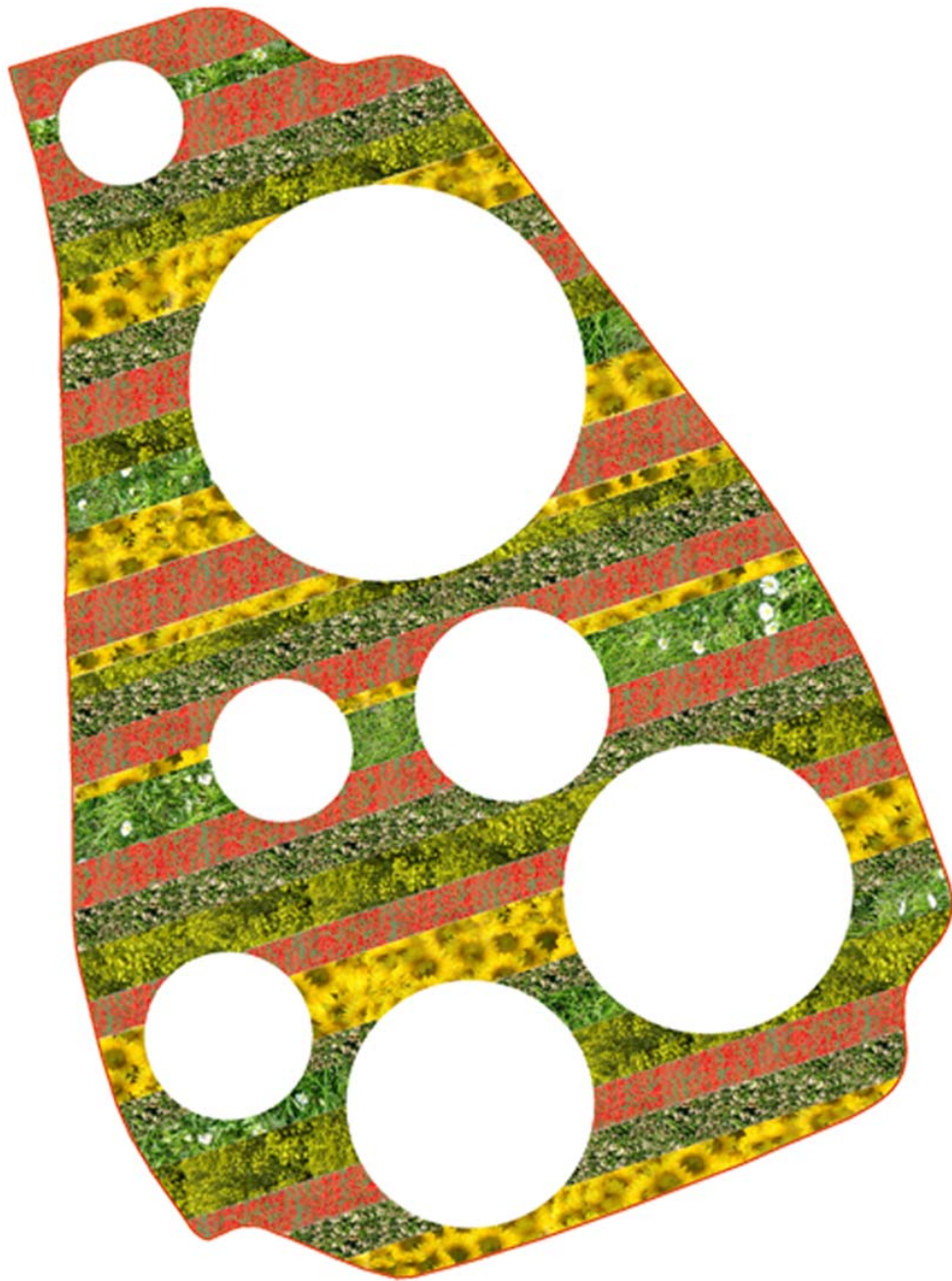





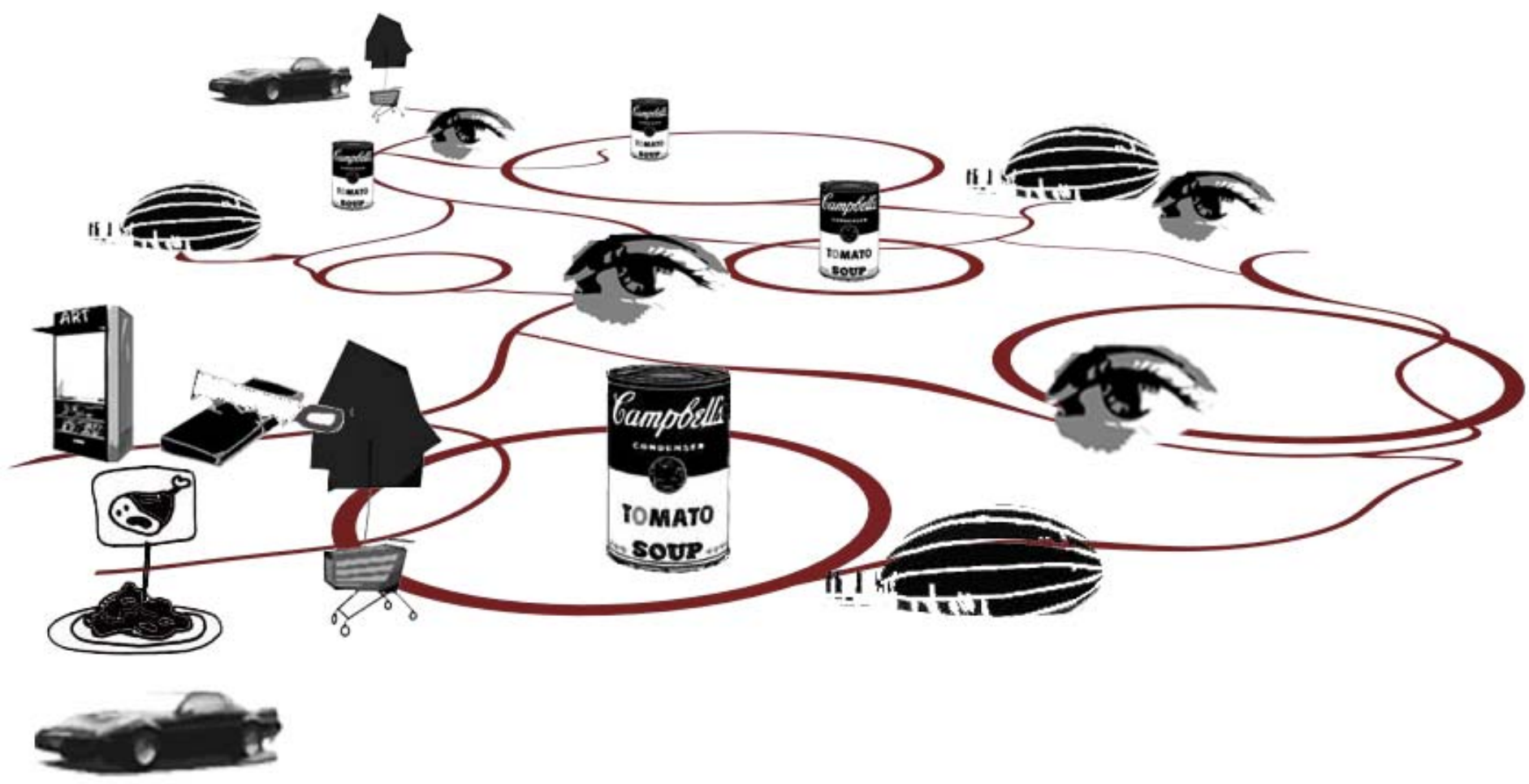



odmarališta







POP ART izložc







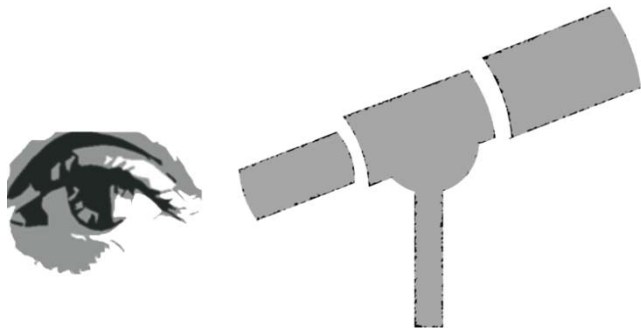

PEVEC



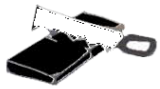

art studio



galerija



parking



restoran



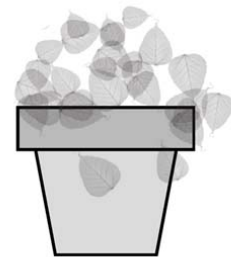
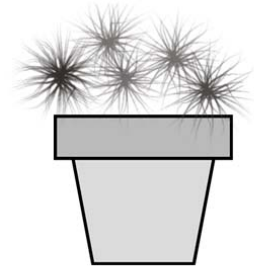
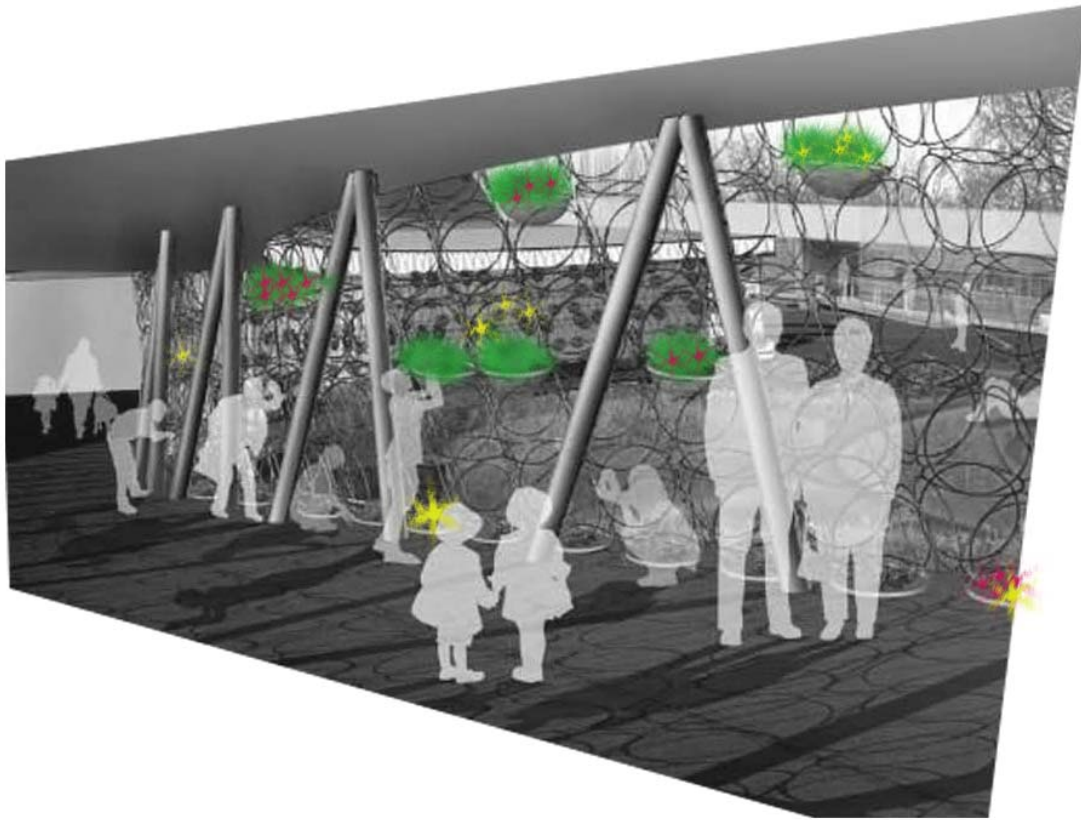



'moving forest







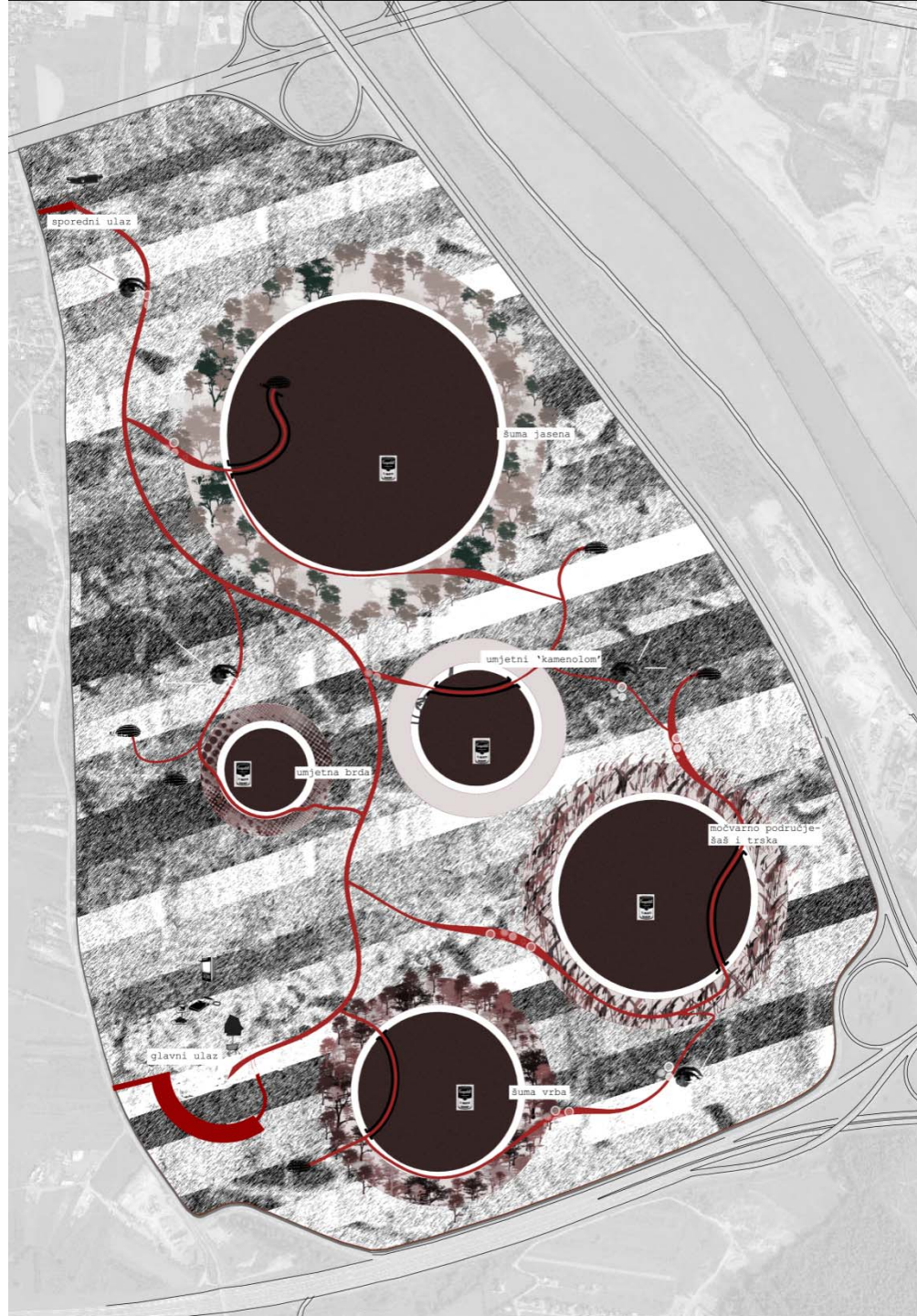

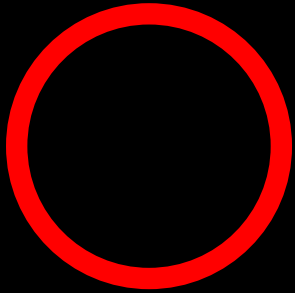

Maja Francuz

**dinamična traka _ idejno rješenje uređenja perivoja stambenog naselja Munja
_ kolegij: perivojno oblikovanje _ IV. semestar _ preddiplomski s**

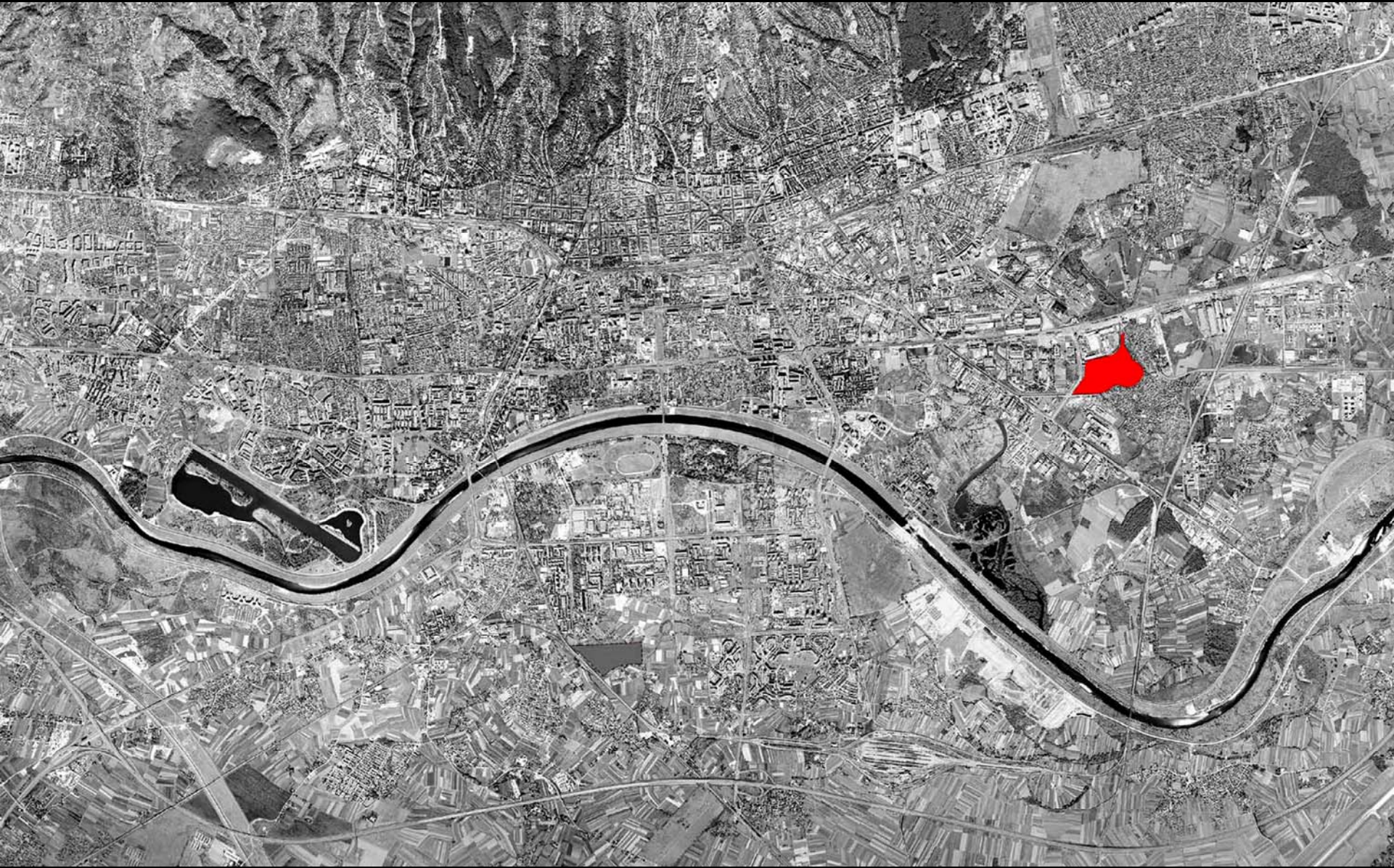

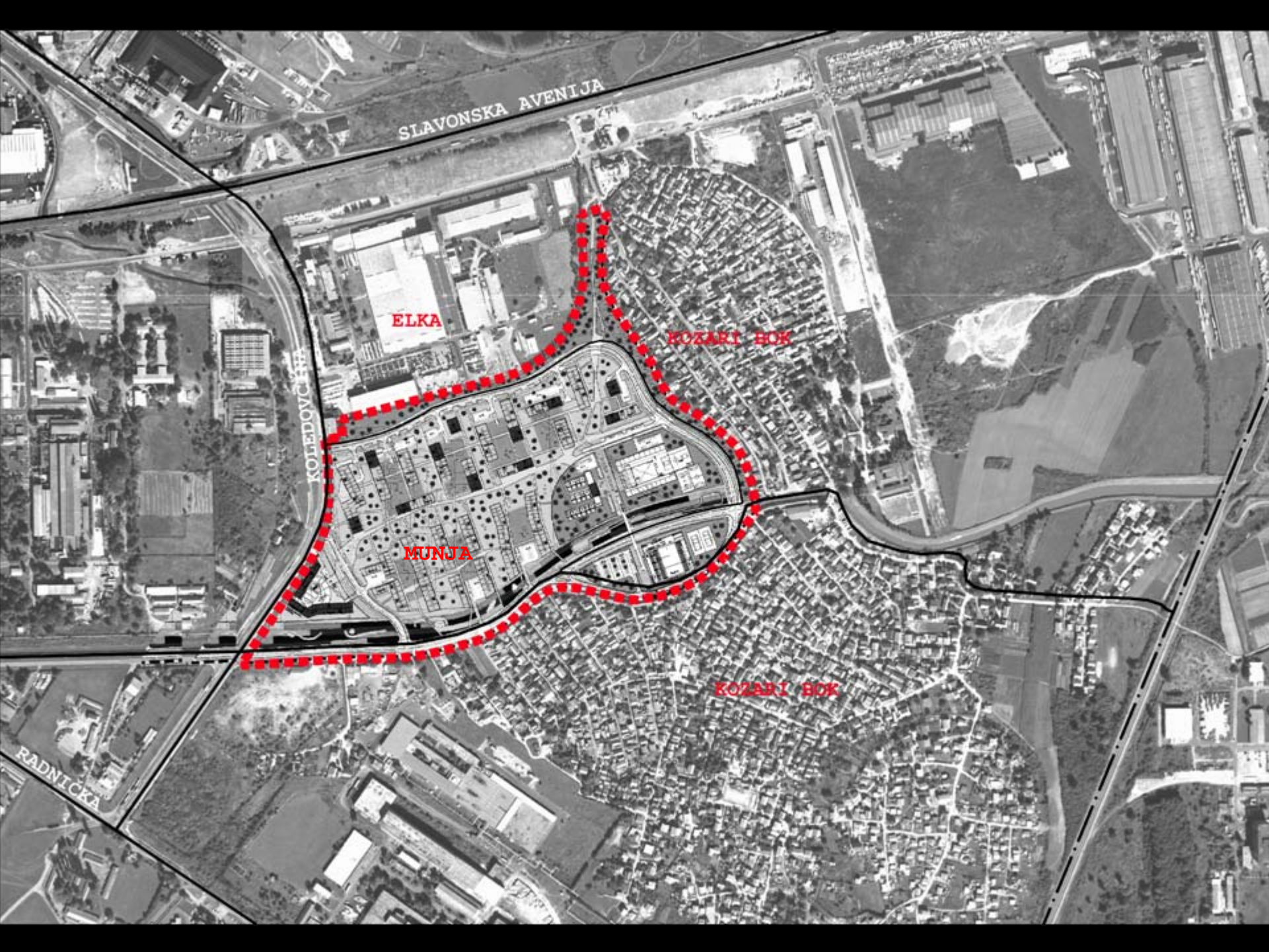

SLAVONSKA AVENIJA

ELKA

KOZARI BOK

MUNJA

KOZARI BOK

KOLEDOVCI

RADNIČKA





POBJEDNIČKI RAD
URBANISTIČKO - ARHITEKTONSKOG NATJEČAJA
UPU MUNJA

autorski tim: **BF STUDIO** d.o.o.

ZORAN BOŠEVSKI, dipl.ing.arh. **BORIS
FIOLIĆ**, dipl.ing.arh. **DAVORKA CINDRIĆ**,
dipl.ing.arh. **TENA ŽIC**, dipl.ing.arh.

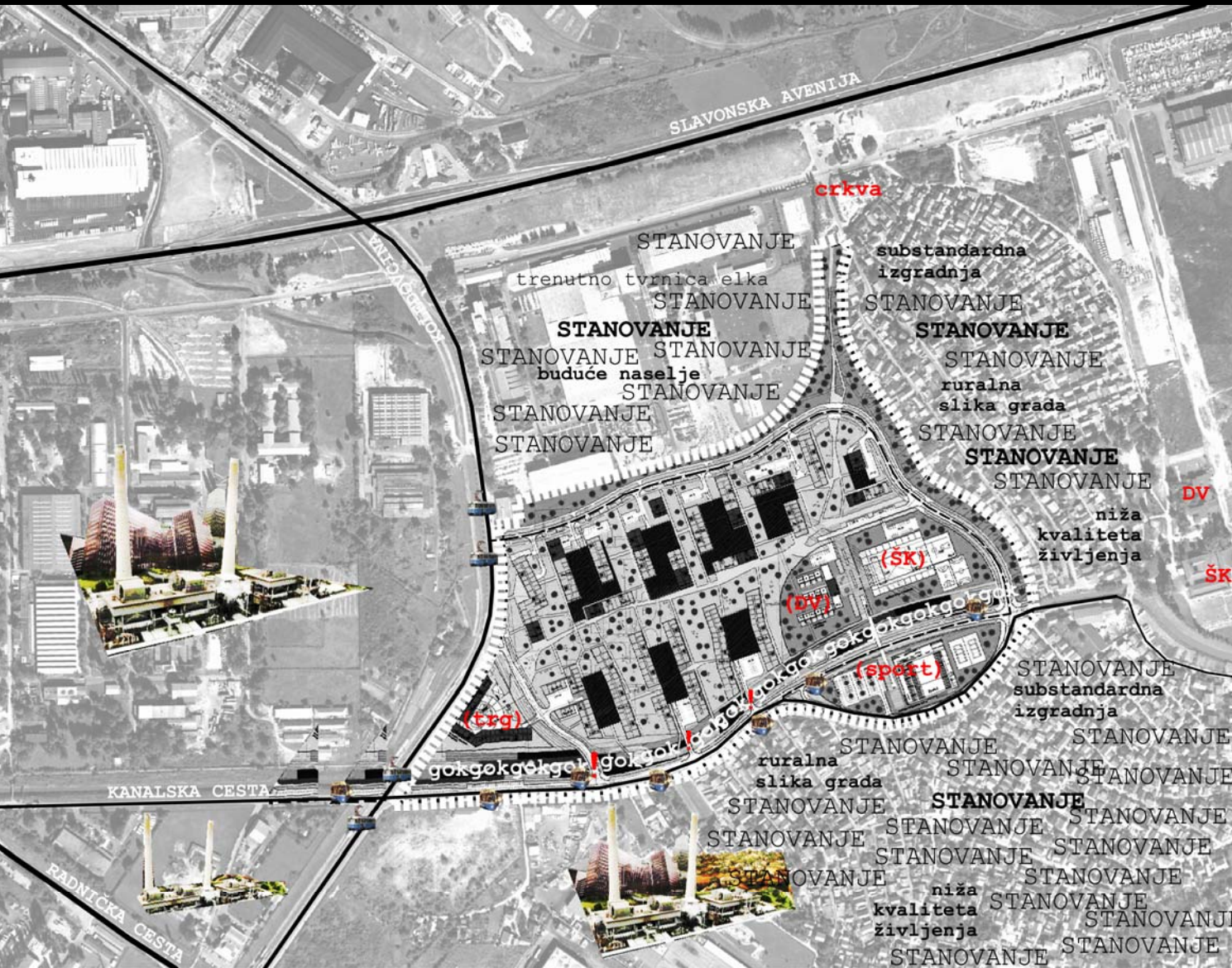

DOBRA PROMETNA POVEZANOST

SUSRET URBANOG I RURALNOG

NEDOSTATAK VEGETACIJE I
JAVNIH SADRŽAJA

INDUSTRIJSKA ZONA GRADA

SLAVONSKA AVENIJA

crkva

STANOVANJE
trenutno tvornica elka
STANOVANJE

substandardna
izgradnja

STANOVANJE
STANOVANJE
buduće naselje
STANOVANJE
STANOVANJE
STANOVANJE

STANOVANJE

STANOVANJE

STANOVANJE

ruralna
slika grada

STANOVANJE

STANOVANJE

STANOVANJE

niza
kvaliteta
življenja

DV

ŠK



(trg)

(DV)

(sport)

STANOVANJE
substandardna
izgradnja

KANALSKA CESTA

gokgokgekgek / gokgok

ruralna
slika grada

STANOVANJE

STANOVANJE

STANOVANJE

STANOVANJE

STANOVANJE

STANOVANJE

STANOVANJE

STANOVANJE

STANOVANJE

STANOVANJE

STANOVANJE

STANOVANJE

niza
kvaliteta
življenja

STANOVANJE

STANOVANJE

STANOVANJE

STANOVANJE



RADNIČKA CESTA

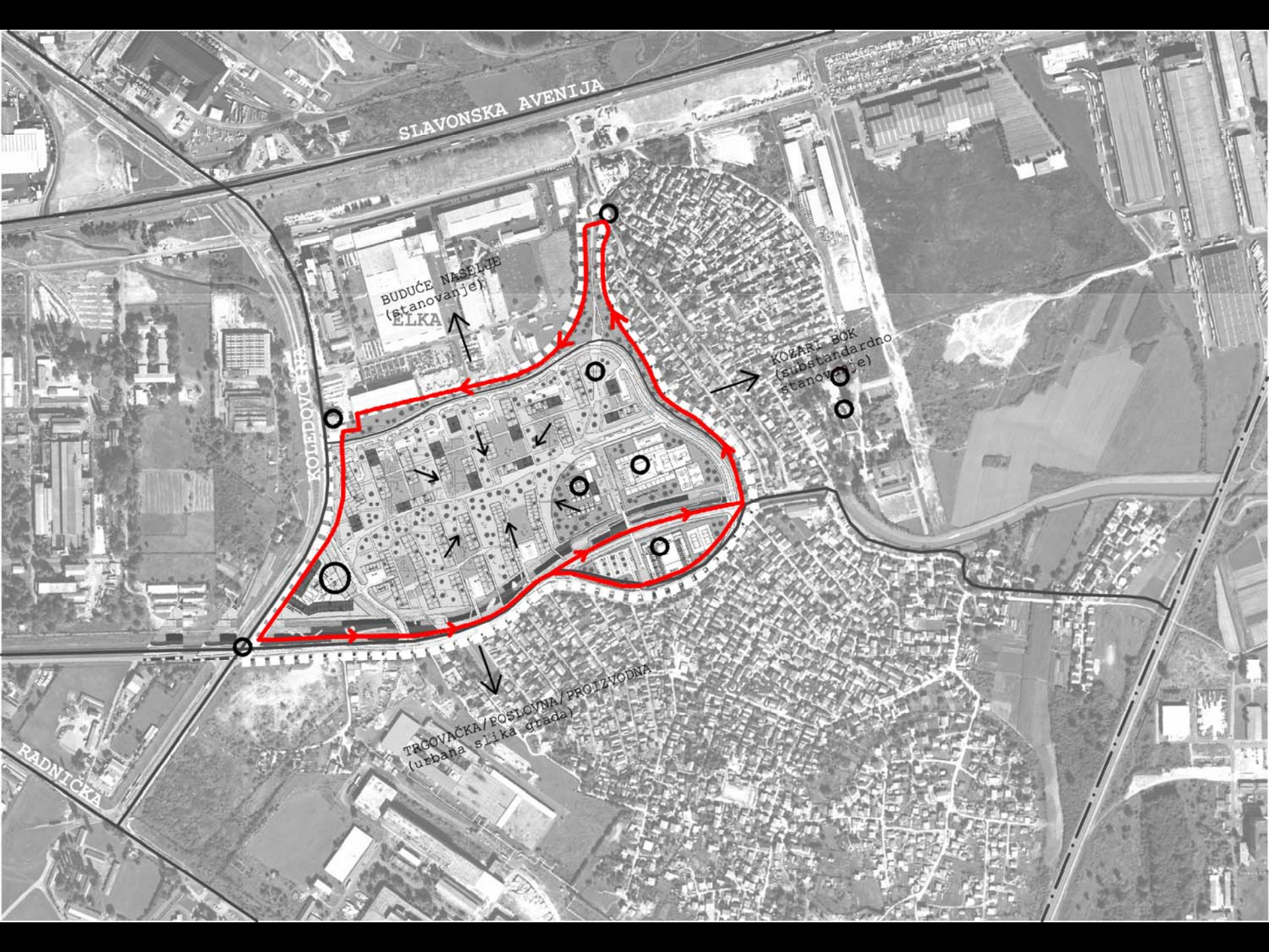

SLAVONSKA AVENIJA

BUDUĆE NASELJE
(stanovanje)
ELKA

KOZARI BOK
(substandardno
stanovanje)

TRGOVAČKA/POSLOVNA/PROIZVODNA
(urbana slika grada)

KOLEDOVČEVA

RADNIČKA



LEGENDA

- podzemne garaže
- visoka vegetacija (park šuma)
- niska vegetacija (dnevni boravci)
- trava
- crni asfalt (dinamična staza)
- popločenje (trg)
- beton (sobe)
- perivojna sipina
- tartan (dječje igralište)
- grupa za sjedenje

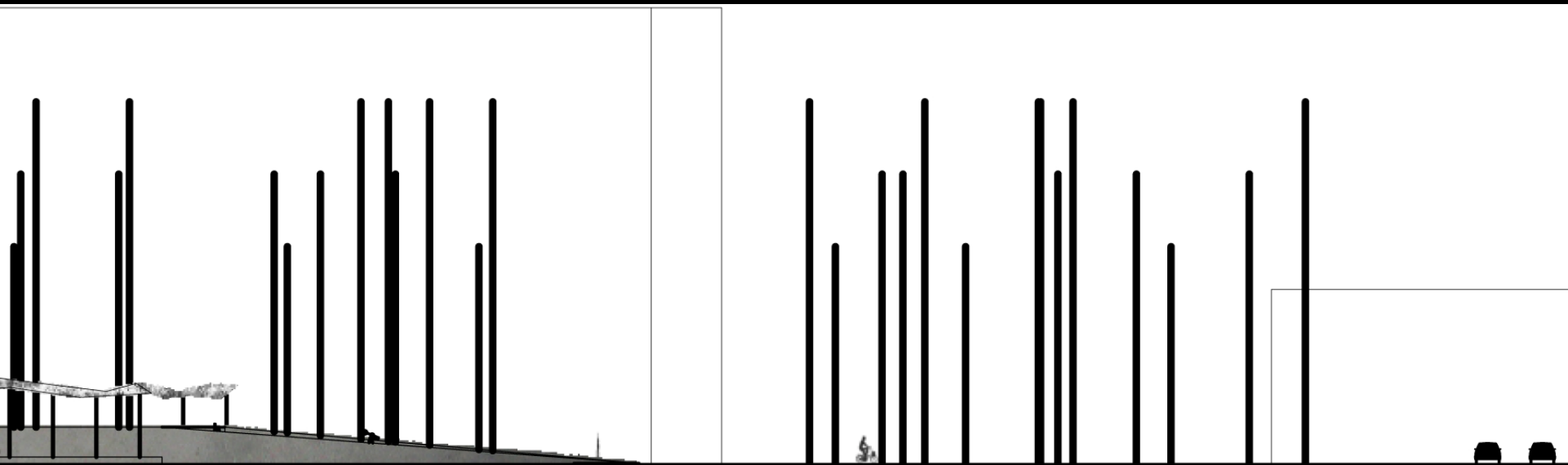

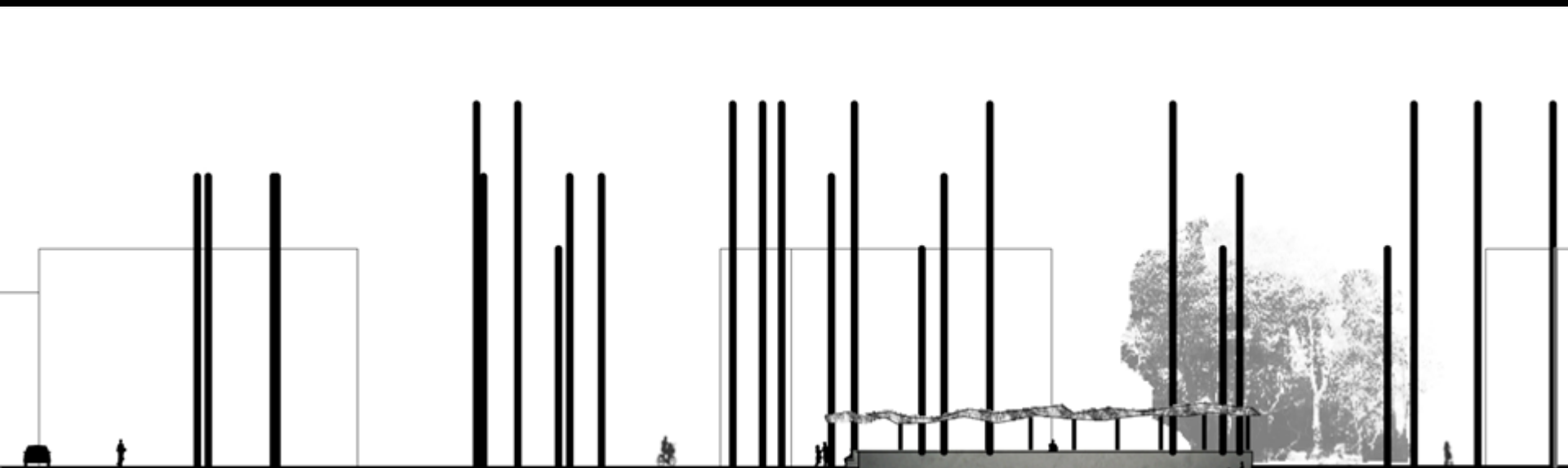

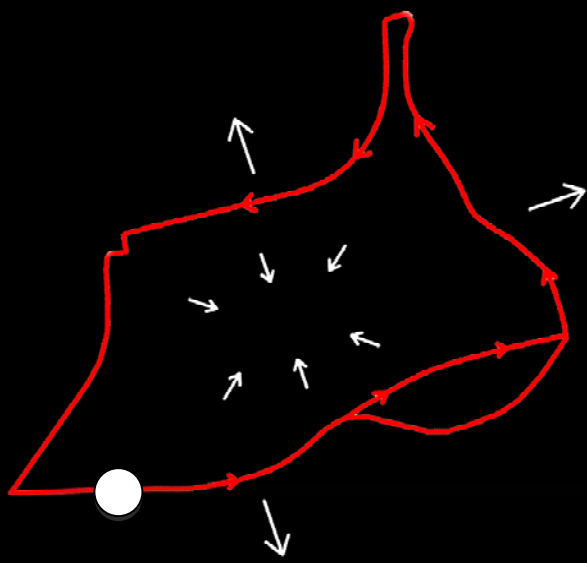

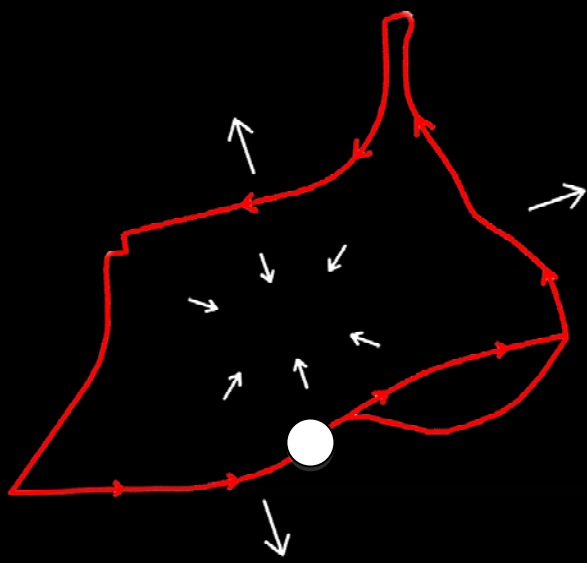

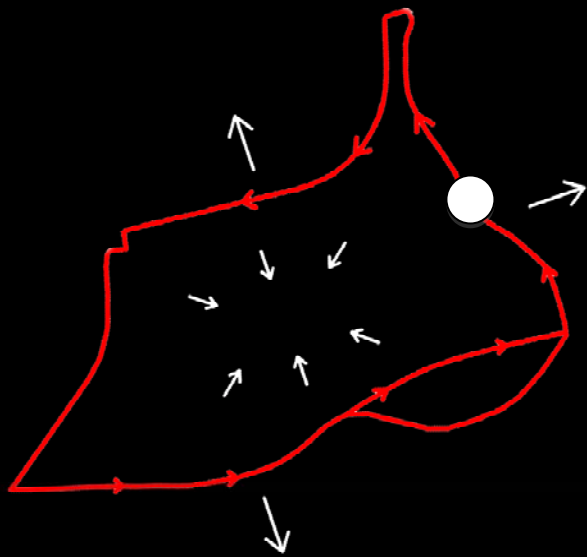

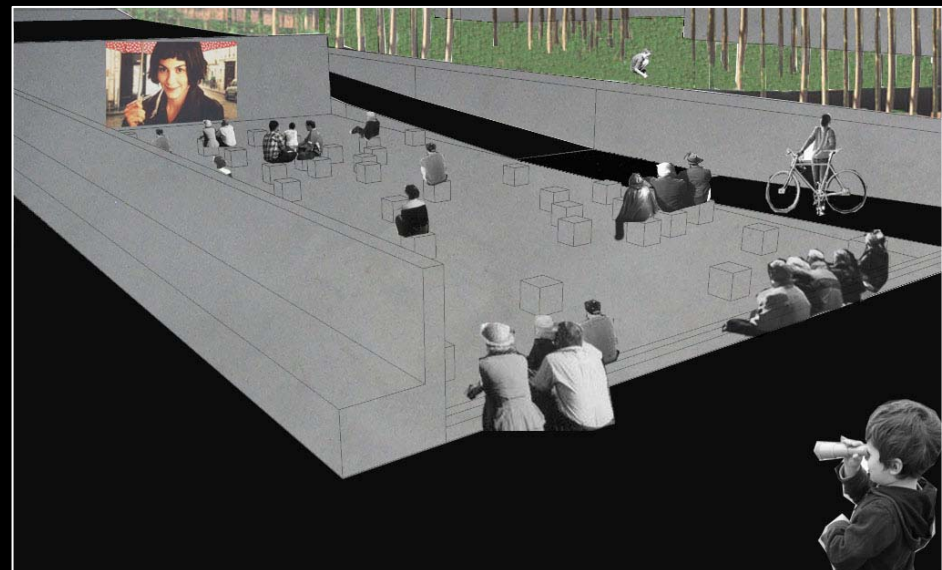

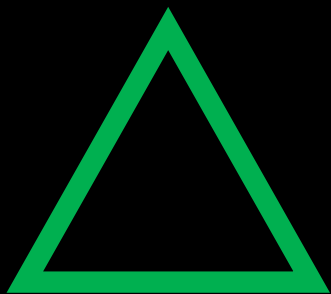

Slaven Letica

green up Mostar _ studentska ljetna radionica 2010



GRIBEN UP!

IZLOŽBA RADIONICE STUDENATA ARHITEKTURE "MOSTARSKI DŽEPNI PERIVOJI"
HRVATSKI DOM HERCEG STJEPAN KOSAČA, NEDJELJA 29.08.2010. U 19:30 SATI
IZLOŽBA ČISTI DVOBIVA DO 12.09.2010.

Arhitektonskog fakulteta Sveučilišta u Zagrebu, Katedre za urbanizam, planiranje i pejzažni dizajn, ova godina je započela nova inicijativa - mreža javnih prostora koja je nastala kao rezultat suradnje i razmjene ideja i projekata. Na sedam različitih zapuštenih odvođenih prostora u Mostaru, započeli su na potrebu drugačijeg tretiranja prostora u organizaciji Arhitektonskog fakulteta Sveučilišta u Zagrebu, Katedre za urbanizam, planiranje i pejzažni dizajn. Akcijama na sedam mikrolokacija zapuštenih prostora u Mostaru, započeli su na potrebu drugačijeg tretiranja prostora u organizaciji Arhitektonskog fakulteta Sveučilišta u Zagrebu, Katedre za urbanizam, planiranje i pejzažni dizajn. Akcijama na sedam mikrolokacija zapuštenih prostora u Mostaru, započeli su na potrebu drugačijeg tretiranja prostora u organizaciji Arhitektonskog fakulteta Sveučilišta u Zagrebu, Katedre za urbanizam, planiranje i pejzažni dizajn. Akcijama na sedam mikrolokacija zapuštenih prostora u Mostaru, započeli su na potrebu drugačijeg tretiranja prostora u organizaciji Arhitektonskog fakulteta Sveučilišta u Zagrebu, Katedre za urbanizam, planiranje i pejzažni dizajn.

Arhitektonskog fakulteta Sveučilišta u Zagrebu, Katedre za urbanizam, planiranje i pejzažni dizajn, ova godina je započela nova inicijativa - mreža javnih prostora koja je nastala kao rezultat suradnje i razmjene ideja i projekata. Na sedam različitih zapuštenih odvođenih prostora u Mostaru, započeli su na potrebu drugačijeg tretiranja prostora u organizaciji Arhitektonskog fakulteta Sveučilišta u Zagrebu, Katedre za urbanizam, planiranje i pejzažni dizajn. Akcijama na sedam mikrolokacija zapuštenih prostora u Mostaru, započeli su na potrebu drugačijeg tretiranja prostora u organizaciji Arhitektonskog fakulteta Sveučilišta u Zagrebu, Katedre za urbanizam, planiranje i pejzažni dizajn. Akcijama na sedam mikrolokacija zapuštenih prostora u Mostaru, započeli su na potrebu drugačijeg tretiranja prostora u organizaciji Arhitektonskog fakulteta Sveučilišta u Zagrebu, Katedre za urbanizam, planiranje i pejzažni dizajn.

“UTJECAJ ARHITEKTURE NA JAVNI PROSTOR”



“UTJECAJ ARHITEKTURE NA JAVNI PROSTOR”



“UTJECAJ JAVNOG PROSTORA NA DOŽIVLJAJ GRADA”



Park Industrial, Barcelona



Park Miro, Barcelona

“UTJECAJ JAVNOG PROSTORA NA OBNOVU GRADA”

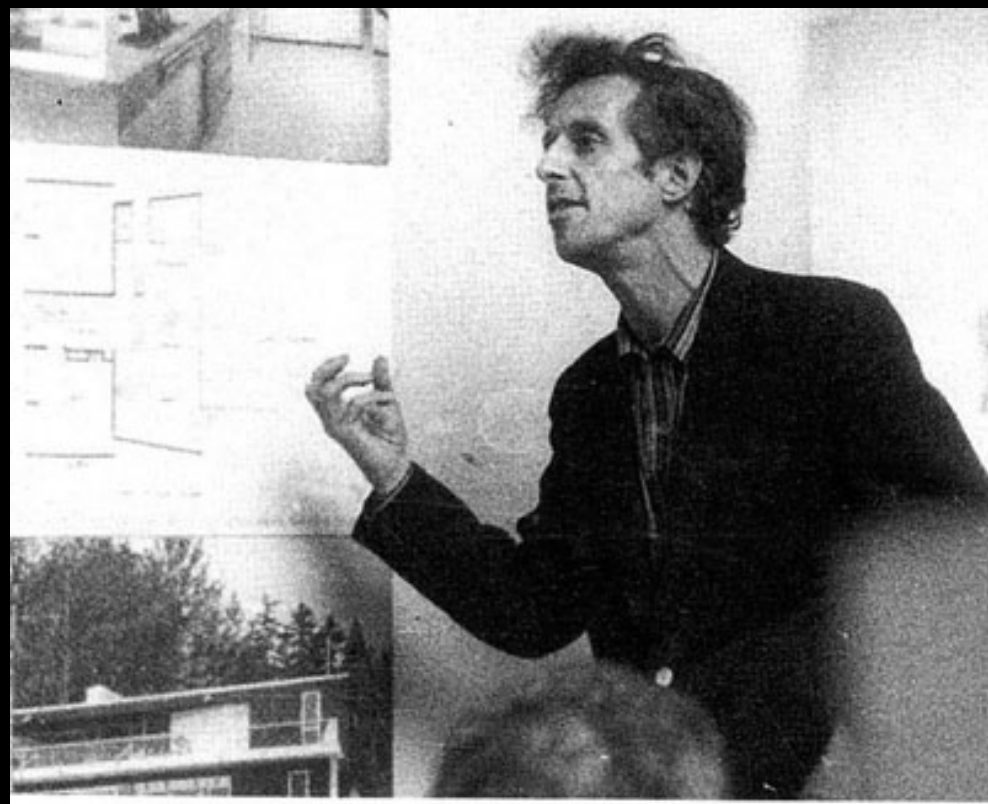

“UTJECAJ JAVNOG PROSTORA NA OBNOVU GRADA”



“UTJECAJ JAVNOG PROSTORA NA OBNOVU GRADA”



Mostar



Mostar – memorijalni park – “Partizansko groblje” , B. Bogdanović



Mostar – memorijalni park – “Partizansko groblje” , B. Bogdanović



Rondo - šetalište



Rondo - šetalište



“Slučaj Mostar”



“Slučaj Mostar”



“Slučaj Mostar”



“Slučaj Mostar”



“Slučaj Mostar”

Pismo čitatelja: Nova mostarska deponija - Centar II

II

Mostar - Obratite pažnju | Nedjelja, 07. Studeni 2010



V eć na rubu živaca zbog smeća koje se taloži danima, nazvala sam J.P. Parkove jutros da pitam da li misle ikada odvesti ovo odurno smeće i jedina koja se javila je tajnica koja mi je rekla da sam pogriješila broj: 320 312. Broj naravno nije pogrešan.

Centar II "pliva" u smeću, a najornija točka je Osnovna škola što se vidi sa slika. Ma naravno, djeca se neće buniti, nemaju kome, a nemamo ni mi sve i da želimo. Šta fali trovat ćemo djecu oni ionako ništa ne znaju.



Ne znam tko je kriv ili uprava ili radnici J.P. Parkova, ali znam da bih se ja na njihovom mjestu sramila svojih postupaka ili bolje reći ne postupaka, razumijem da se ljudima ne radi ako ne primaju plaće, ali iskreno i kada primaju plaće i kada odvoze smeće, zona oko kontejnera je više nego odurna.

Roneći preko ulice!

Mostar - Obratite pažnju | Srijeda, 10. Studeni 2010



K analizacijska mreža je dotrajala, rađena za 80-te godine prošlog stoljeća. Računajući i na uništenu kanalizacionu mrežu za vrijeme ratnih događanja te njezino oživljavanjem, više je nego jasno da ne može postojeća kanalizacija adekvatno prihvatiti i preuzeti sve oborinske vode koje se za vrijeme velikih oborina slijevaju u sustav oborinske kanalizacije, rekao je za **Dnevni list** načelnik Odjela za gospodarstvo, komunalne i inspeksijske poslove GU-a Mostar Omer Pajić.



foto: bljesak.info

Posebno je naglasio kako divlji priključci na kanalizacionu mrežu nisu velik problem, te je dodao kako najveći problem koji treba riješiti je pitanje rekonstrukcije kanalizacione mreže u gradu Mostaru.

Studentska arhitektonsko-urbanistička radionica u organizaciji **Arhitektonskog fakulteta Sveučilišta u Zagrebu**, Katedre za urbanizam, prostorno planiranje i pejzažnu arhitekturu i **Grada Mostara** pokrenuta je po prvi puta sa željom osmišljanja novog identiteta zapuštenih površina unutar stambenih četvrti grada. **Pejzažna infrastruktura grada** - parkovi, perivoji, trгови, drvoredi - **mreža javnih prostora** koja je nekada predstavljala jedno od glavnih obilježja **slike Mostara**, danas je izgubljena. Postupnim zapuštanjem iste gubi se identitet grada, zaboravlja se **kultura urbanog života**, zapostavlja se **socijalizacija** i prekida osjećaj pripadnosti prostoru - naselju, gradu, pejzažu. Akcijama na **sedam mikrolokacija** ove godine je započeta nova inicijativa - malim zahvatima do velikih promjena. Na sedam različitih zapuštenih otvorenih prostora stambenih naselja studenti su osmislili nove javne prostore za Mostar. Kreativnim idejama i suvremenim oblikovanjem ukazali su na potrebu drugačijeg tretiranja javnih prostora grada. **Novi džepni perivoji** - prostori malog mjerila, a velikog značaja.

GREEN UP! - lokacije



GREEN UP! - lokacije



GREEN UP! - lokacije



GREEN UP! - lokacije



GREEN UP! - lokacije



GREEN UP!



Naslovnica Regije Kolumne Multimedija Forum

Izdanje: Hrvatska | BiH

vecernji.hr

AKTUALNO BIZNIS SPORTAL KULTURA SCENA ŽIVOT REGIJE ZAGREB

Večernji fm | E-izdanje | Večernji shop | Pretplata | Moj Večernji | Predajoglas | Login | Facebook



Marko Karačić/VLM OBJAVA: 24.08.2010 / 08:10 PRIKAZA: 432

Mostar dobiva sedam novih parkova

Projekt je osmislio mladi mostarski arhitekt, koji će zajedno sa svojim mentorima raditi na idejnim rješenjima za sedam parkova u Mostaru.

Preporučiti Budite prvi

MAGAZINE business

- Home
- Prilog
- Tema
- Raport



AbrasMEDIA društveno angažirani mediji

Francuski kulturni centar Media Balkanika! Audio Video

Utorak, 24. KOLOVOZ 2010 08:55

Mladi mostarski arhitekt: Mostar dobiva sedam novih parkova

AUTOR ROBI

Krajem ovoga mjeseca u Mostar dolazi više od 20 studenata arhitekture iz Zagreba, koji će zajedno sa svojim mentorima raditi na idejnim rješenjima za sedam parkova u Mostaru.

Inicijativu za ovaj projekt je pokrenuo Slaven Letica, apsolutno spomenutog studija, na koji je prije četiri godine otišao iz Mostara.

AbrasMEDIA Zurnal 6 part 1

YouTube

00:00 / 14:12

www.prag.ba

Sedam parkova za Mostar



www.prag.ba



GREEN UP!

- preformance
- projekt/realizacija
- izložba



GREEN UP! – preformance: anketa i provokacija



GREEN UP! – preformance: anketa i provokacija



GREEN UP! – preformance: anketa i provokacija



GREEN UP! – preformance: anketa i provokacija



GREEN UP! – preformance: anketa i provokacija



GREEN UP! – projekt/realizacija



GREEN UP! – projekt/realizacija



GREEN UP! – projekt/realizacija



GREEN UP! – projekt/realizacija



GREEN UP! – izložba



GREEN UP! – izložba



GREEN UP! – izložba



GREEN UP!



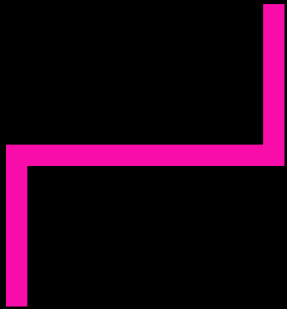

Tina Galešić, Tanja Haraminčić, Lea Kovač

**pink link _ idejno rješenje džepnog perivoja u Mostaru
_ studentska ljetna radionica _ green up Mostar**



Mostar: javni prostor danas



Flower power





Christmas tree





Parking ticket





Balloons





Mostar: javni prostor prije



Mostar: javni prostor prije



How can a city expand onto a river?, Ljubljana, 2006. - ProstoRož



How can a city expand onto a river?, Ljubljana, 2006. - ProstoRož



Sardine - instalacija, Ljubljana, 2008.



Murinsel, Graz, 2003. - Vito Ancoci

Položaj u gradu

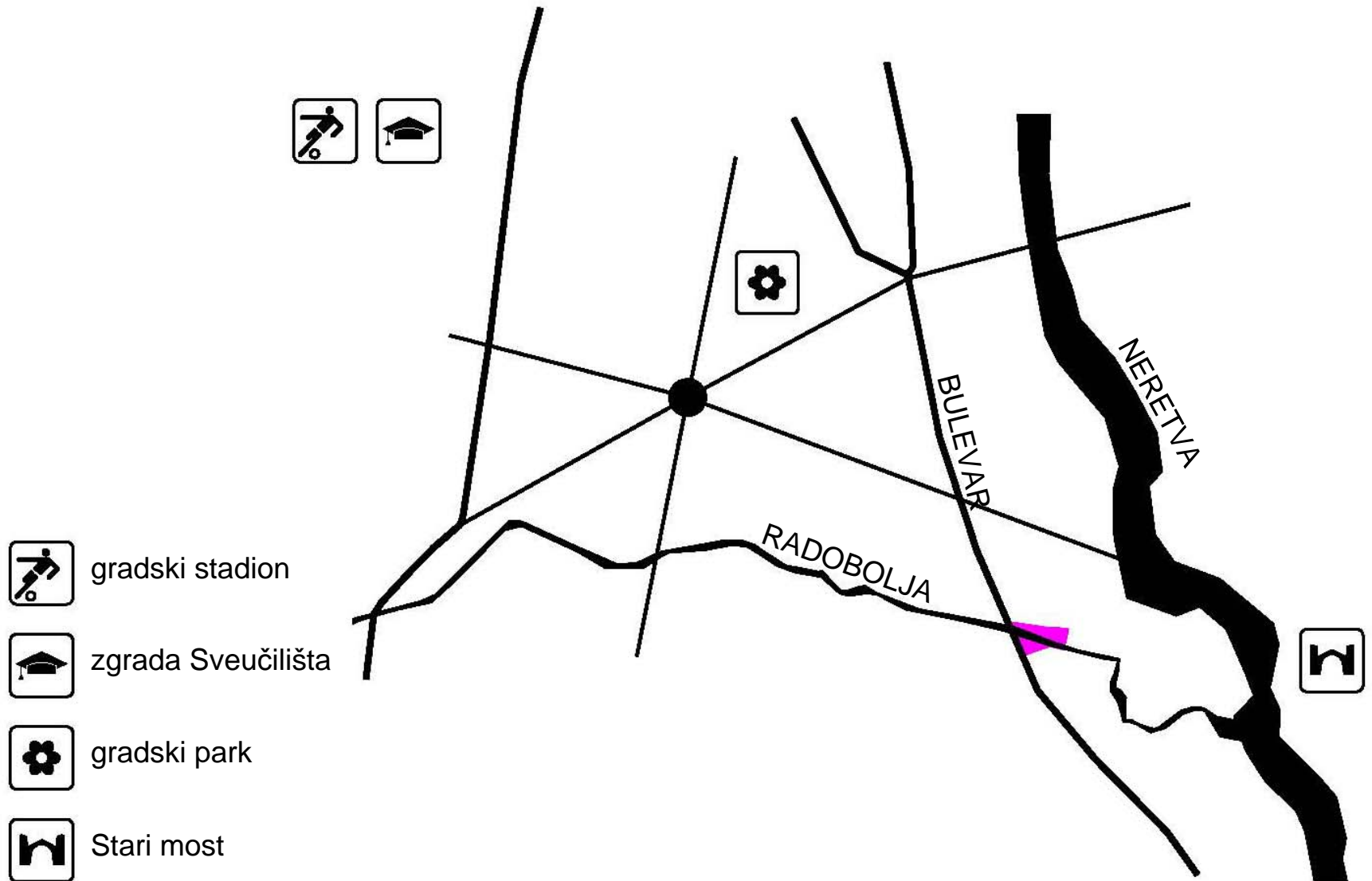

Šira situacija

| 0

| 10

| 50

| 100

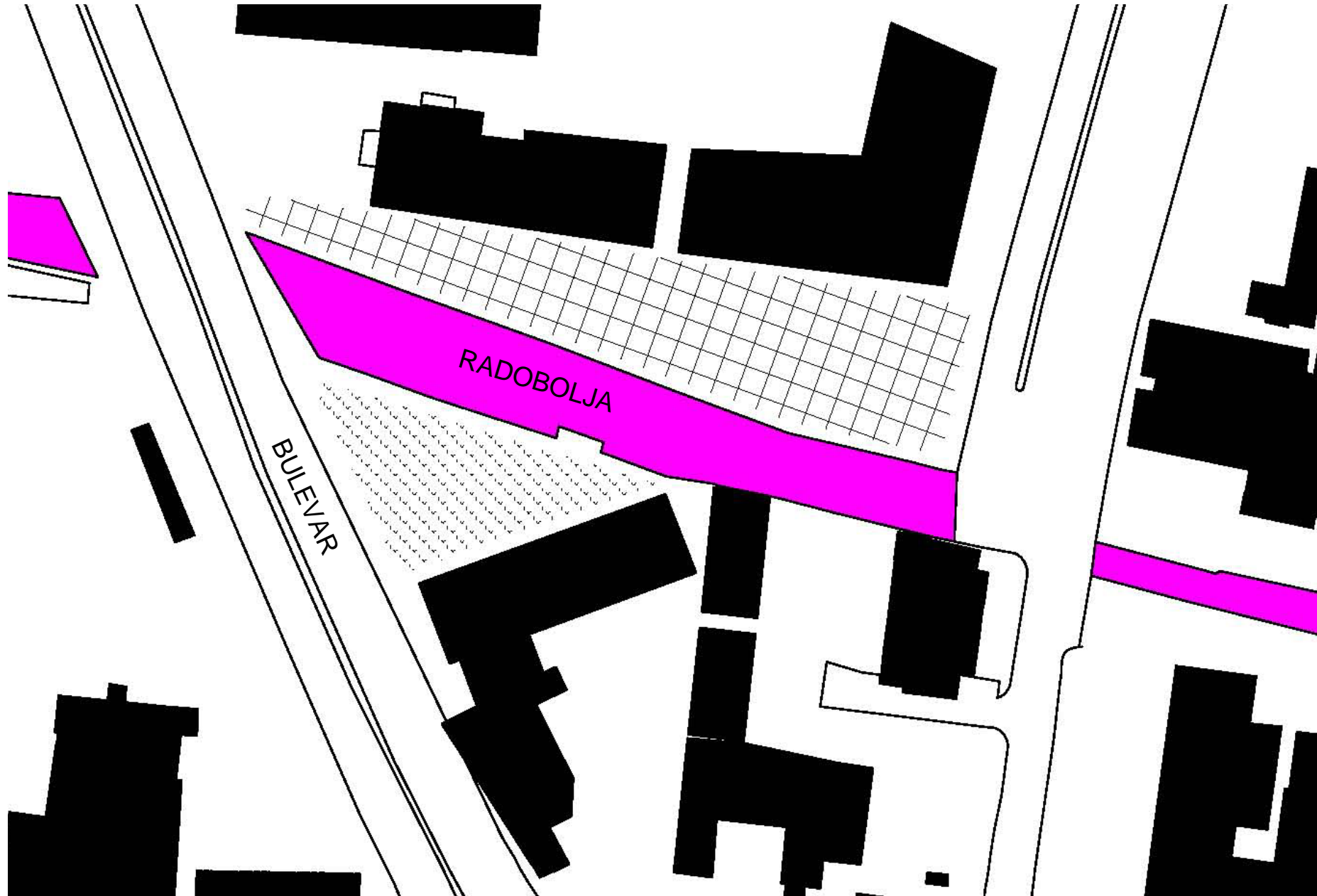



nekontrolirani rast samoniklih biljnih vrsta



neodržavano riječno korito



slab interes stanara za održavanje područja



trenutno (ne)korištenje prostora | nezbrinjavanje otpada



promjenjiv vodostaj rijeke



blizina autobusne stanice | potencijal temeljen na smještaju

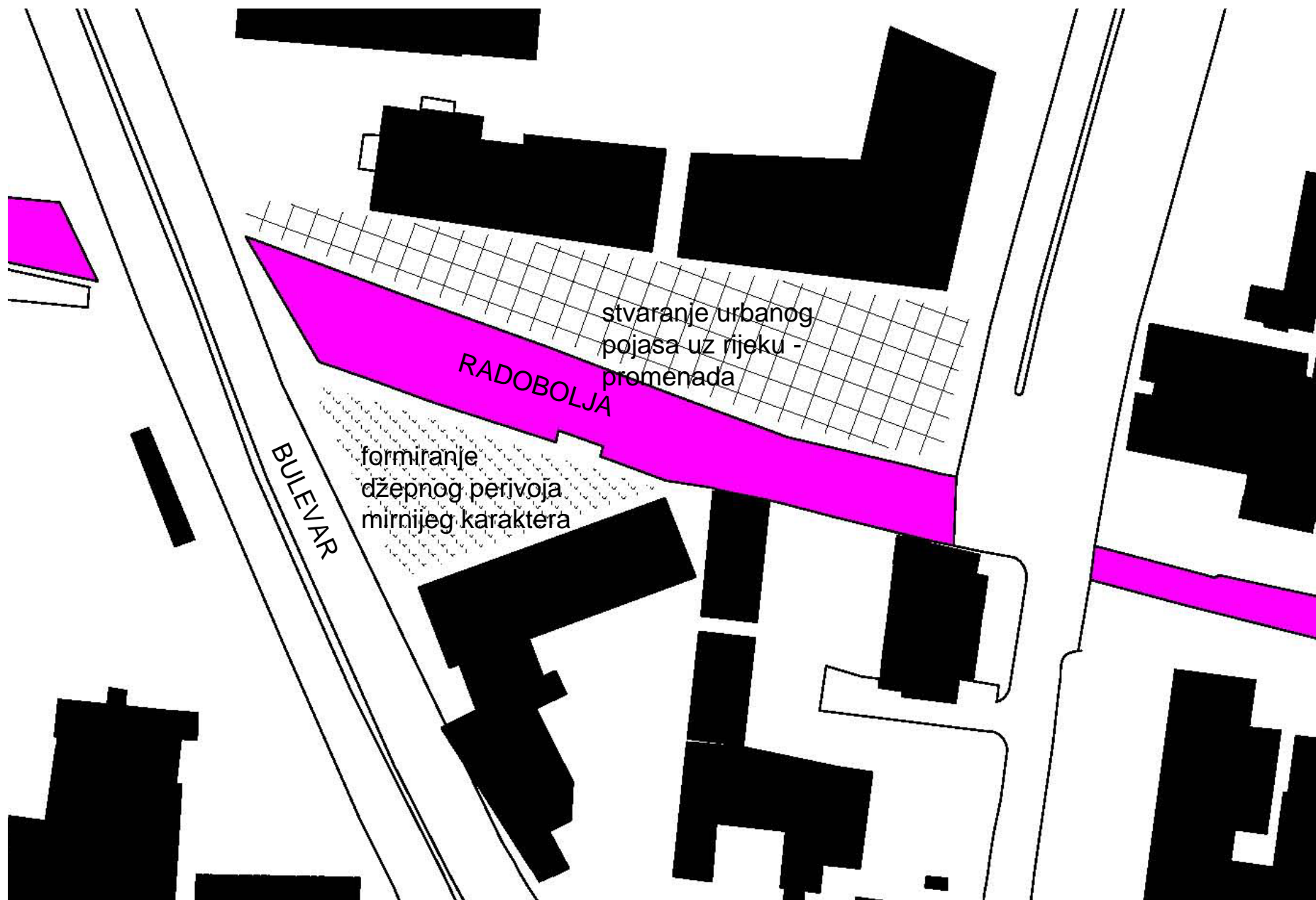

stvaranje urbanog
pojasa uz rijeku -
promenada

RADOBOLJA

formiranje
džepnog perivoja
mirnijeg karaktera

BULEVAR

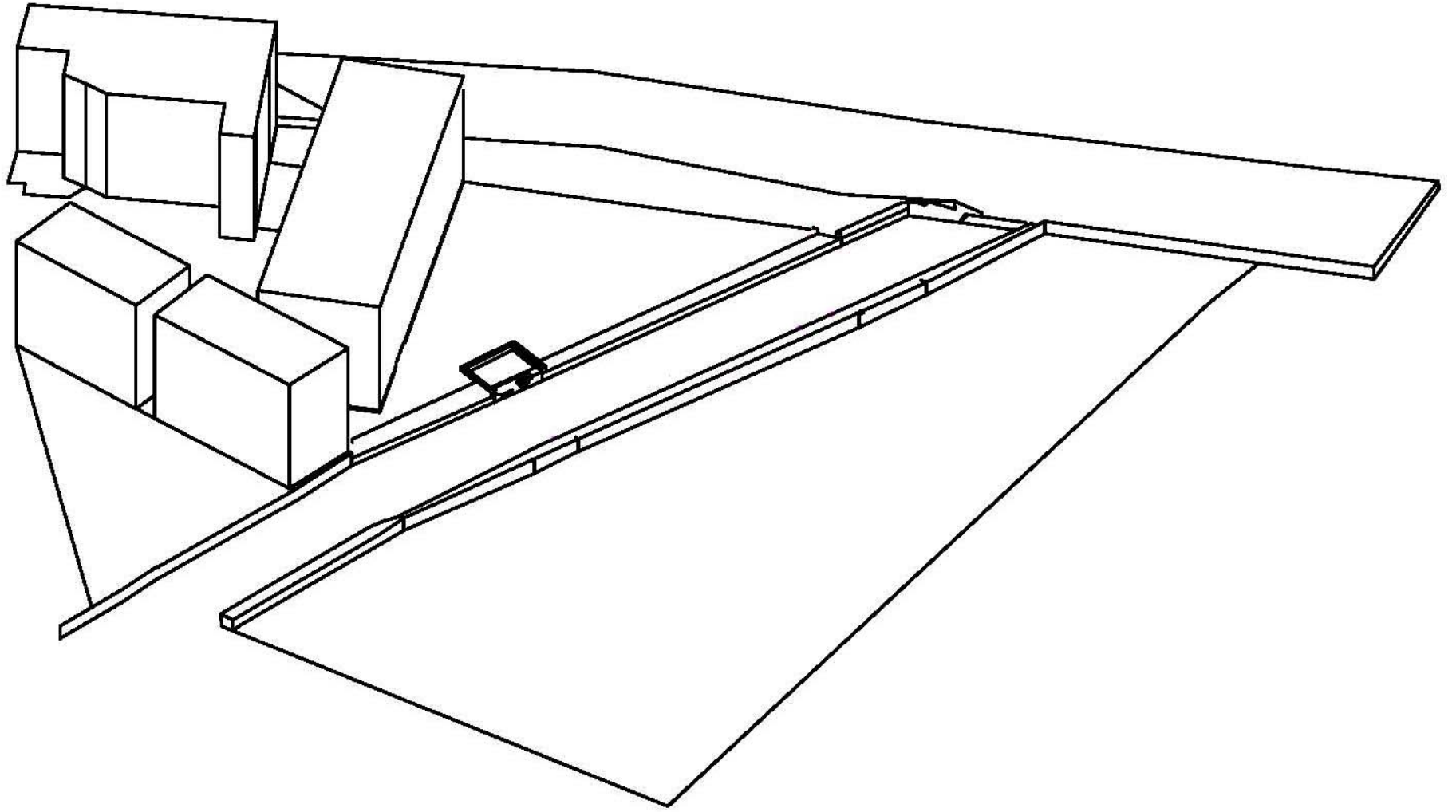

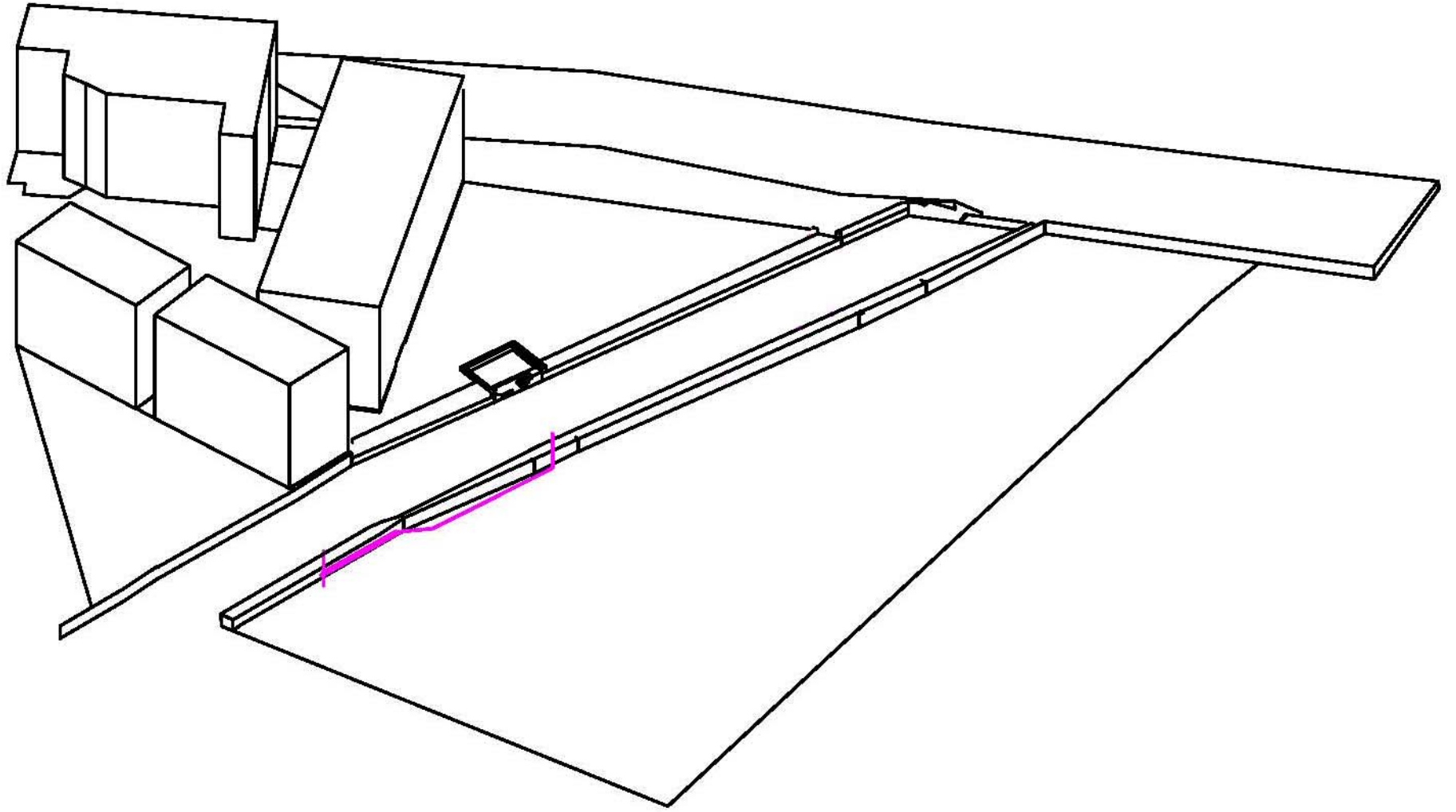

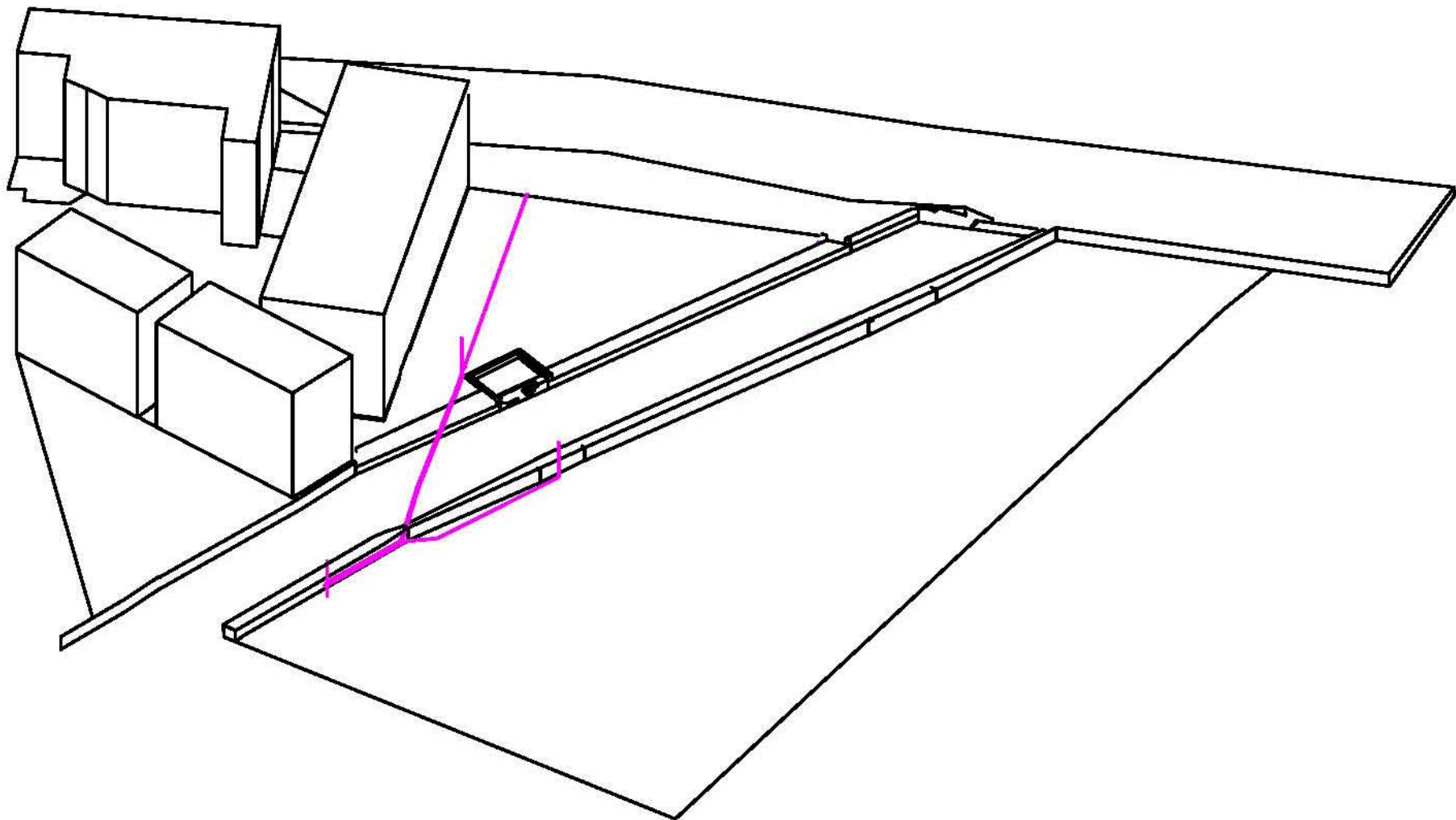

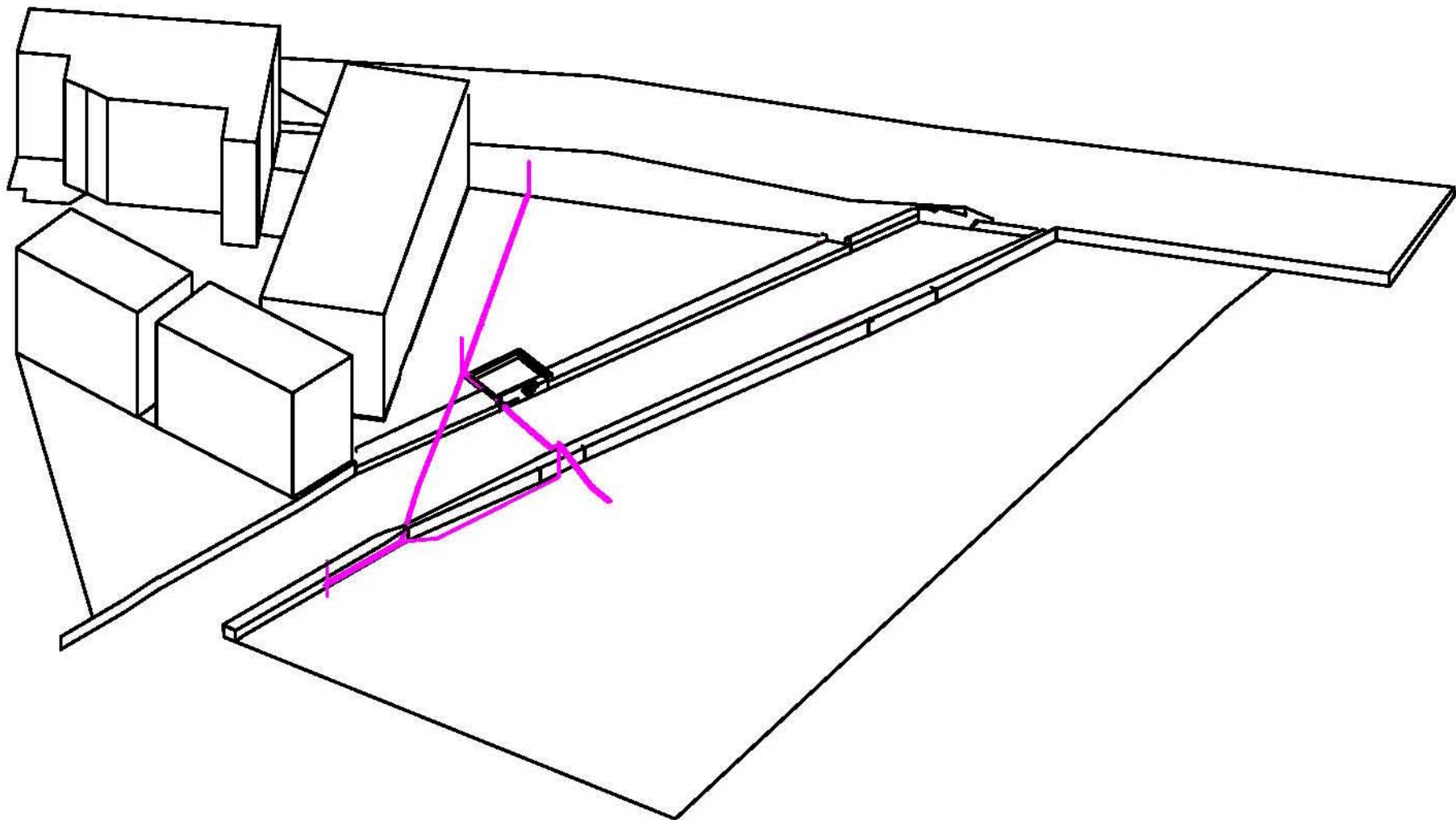

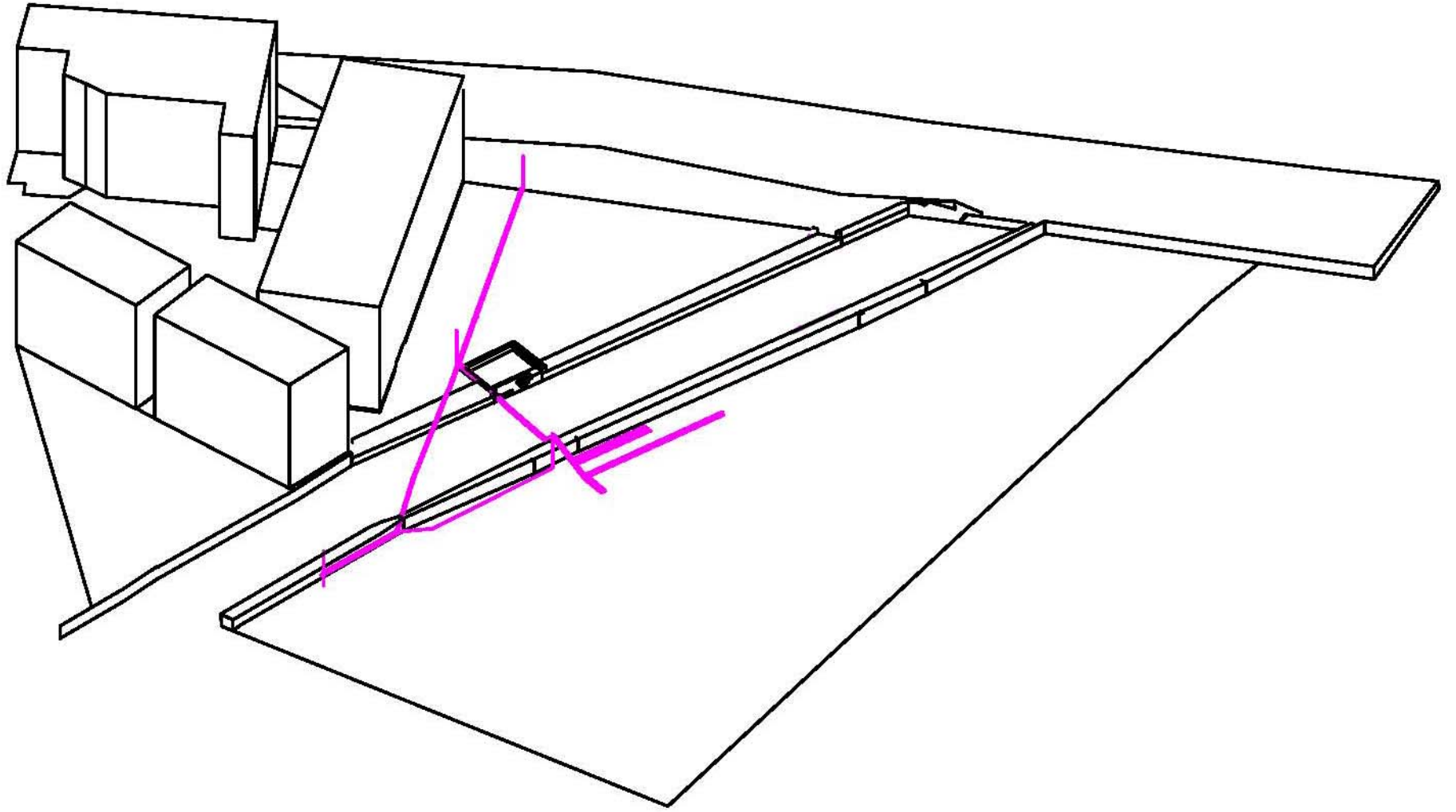

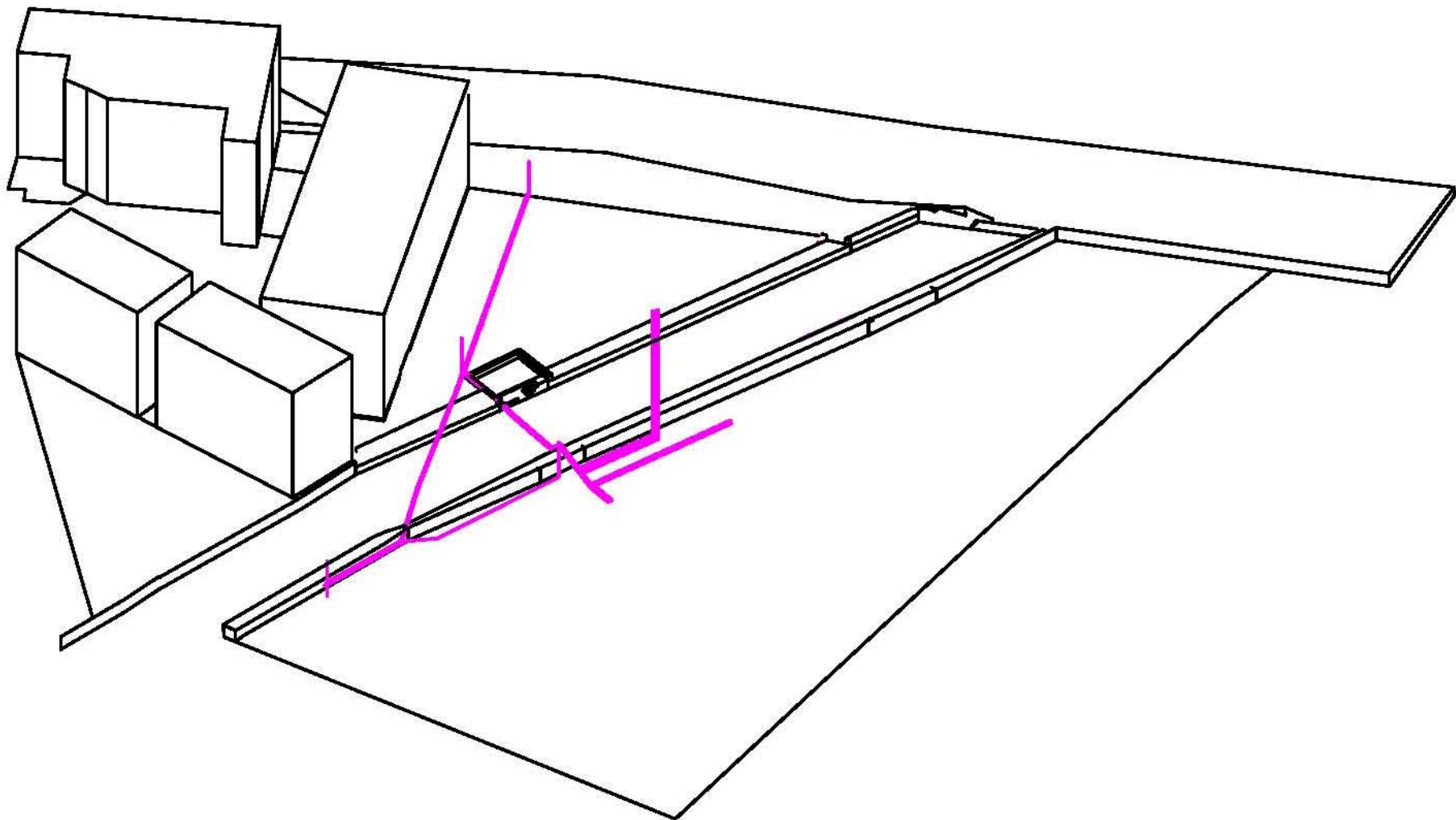

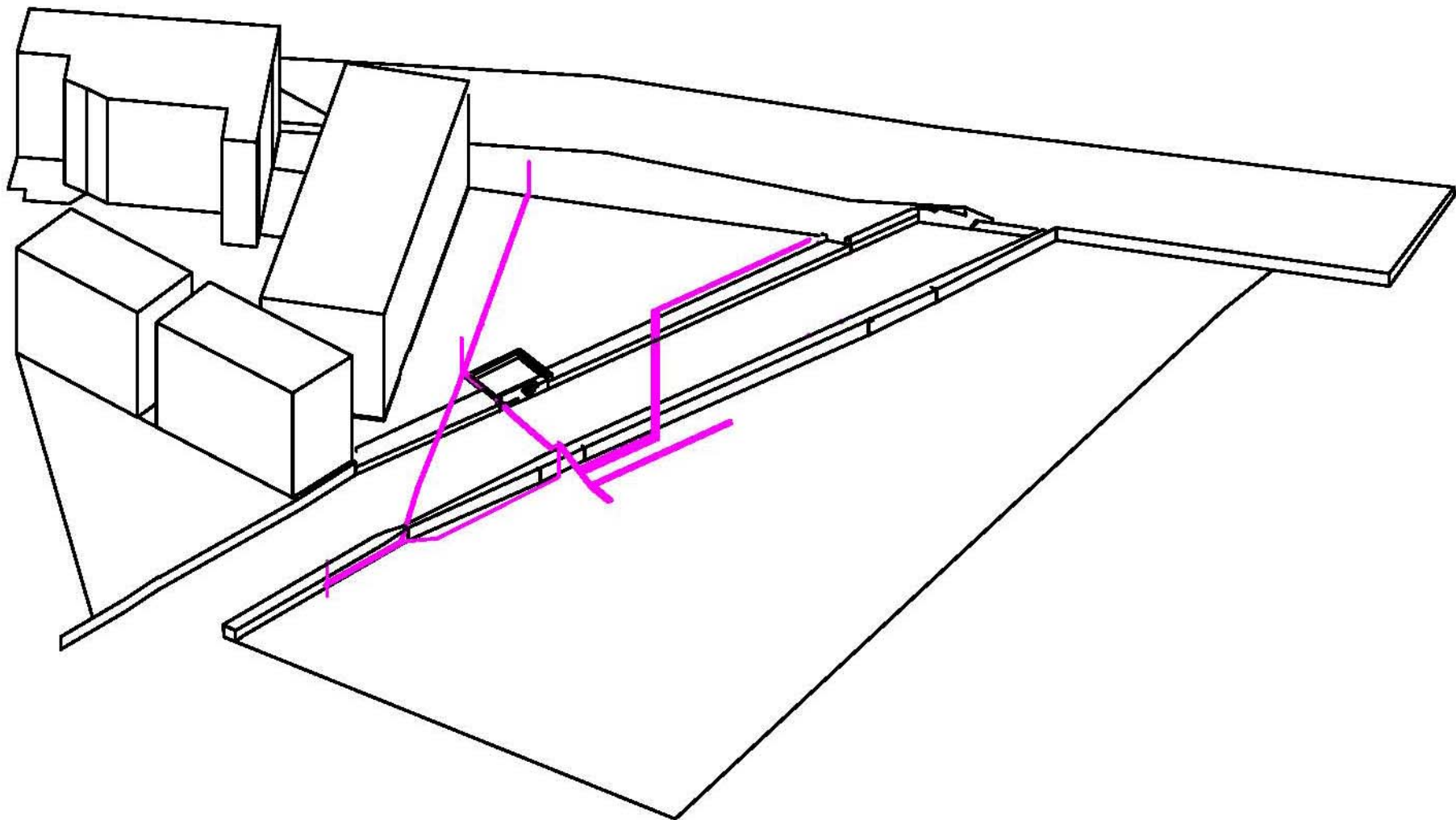

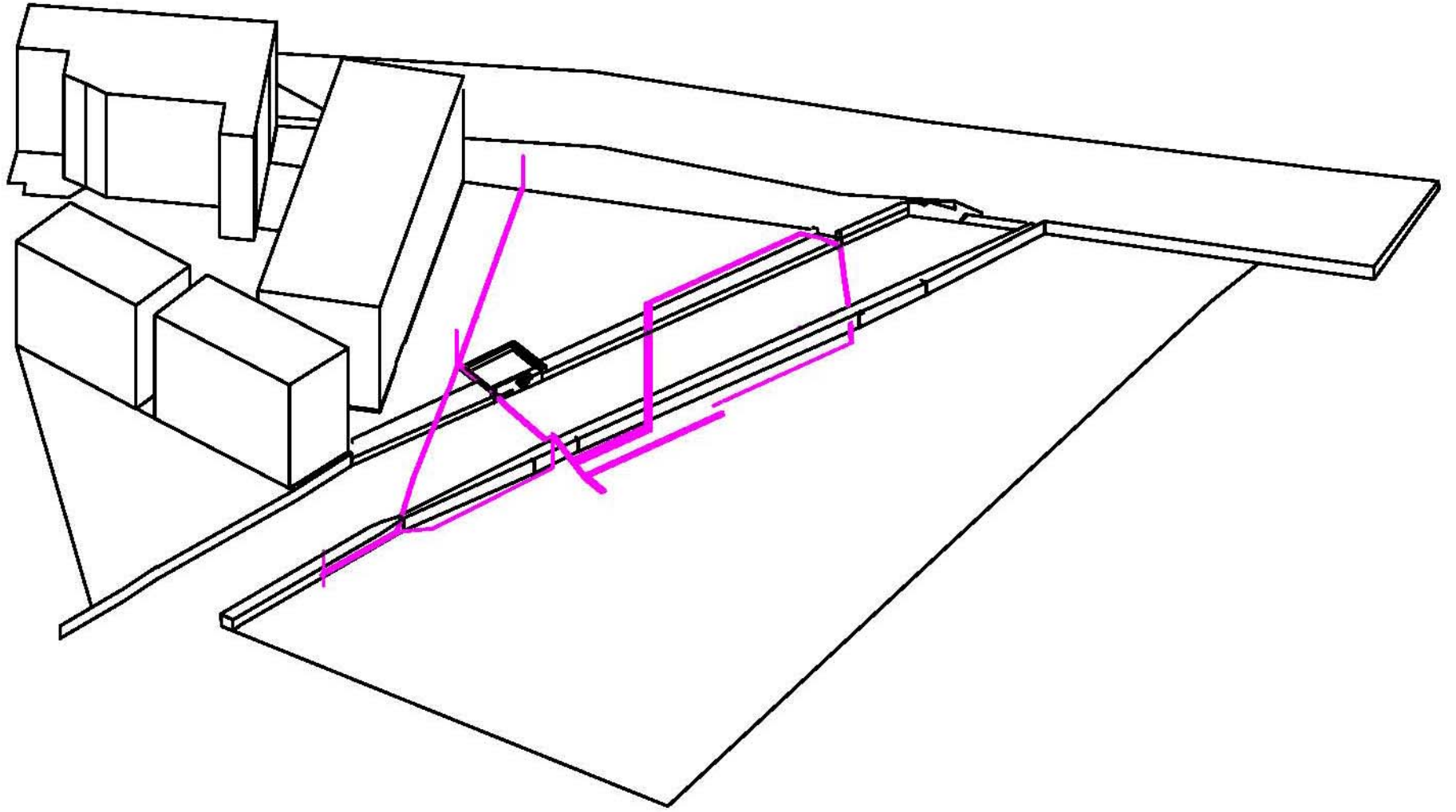

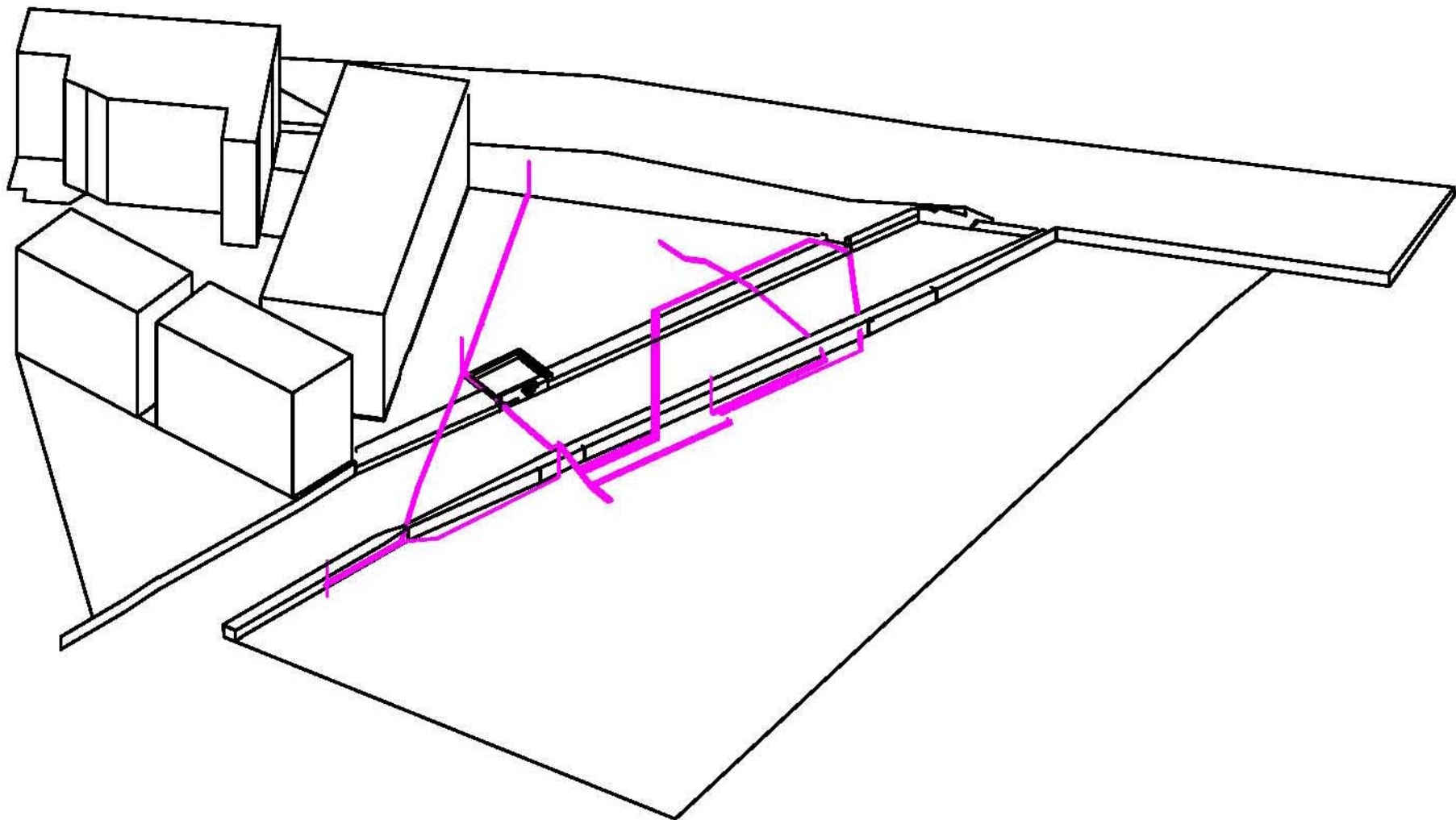

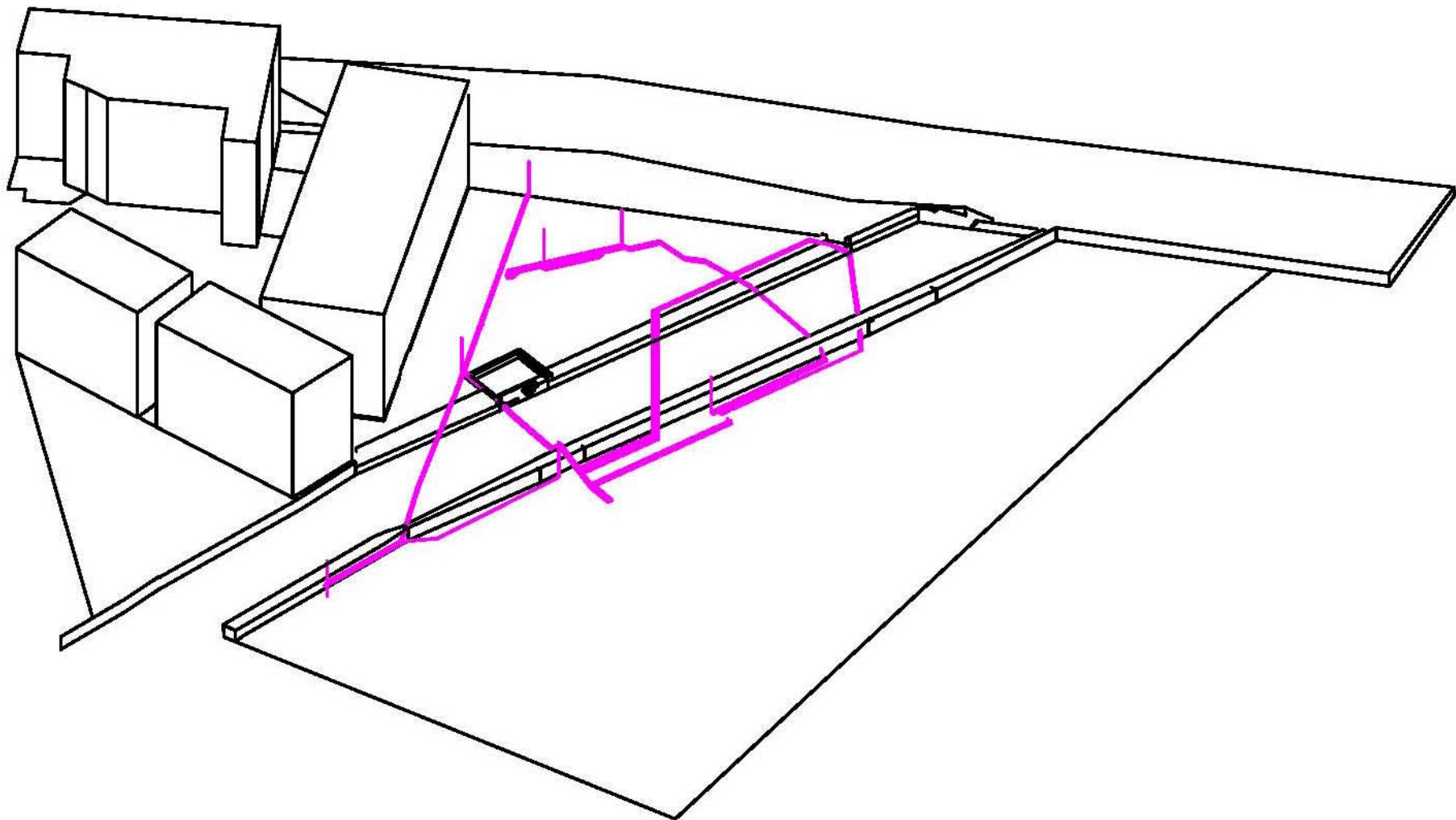

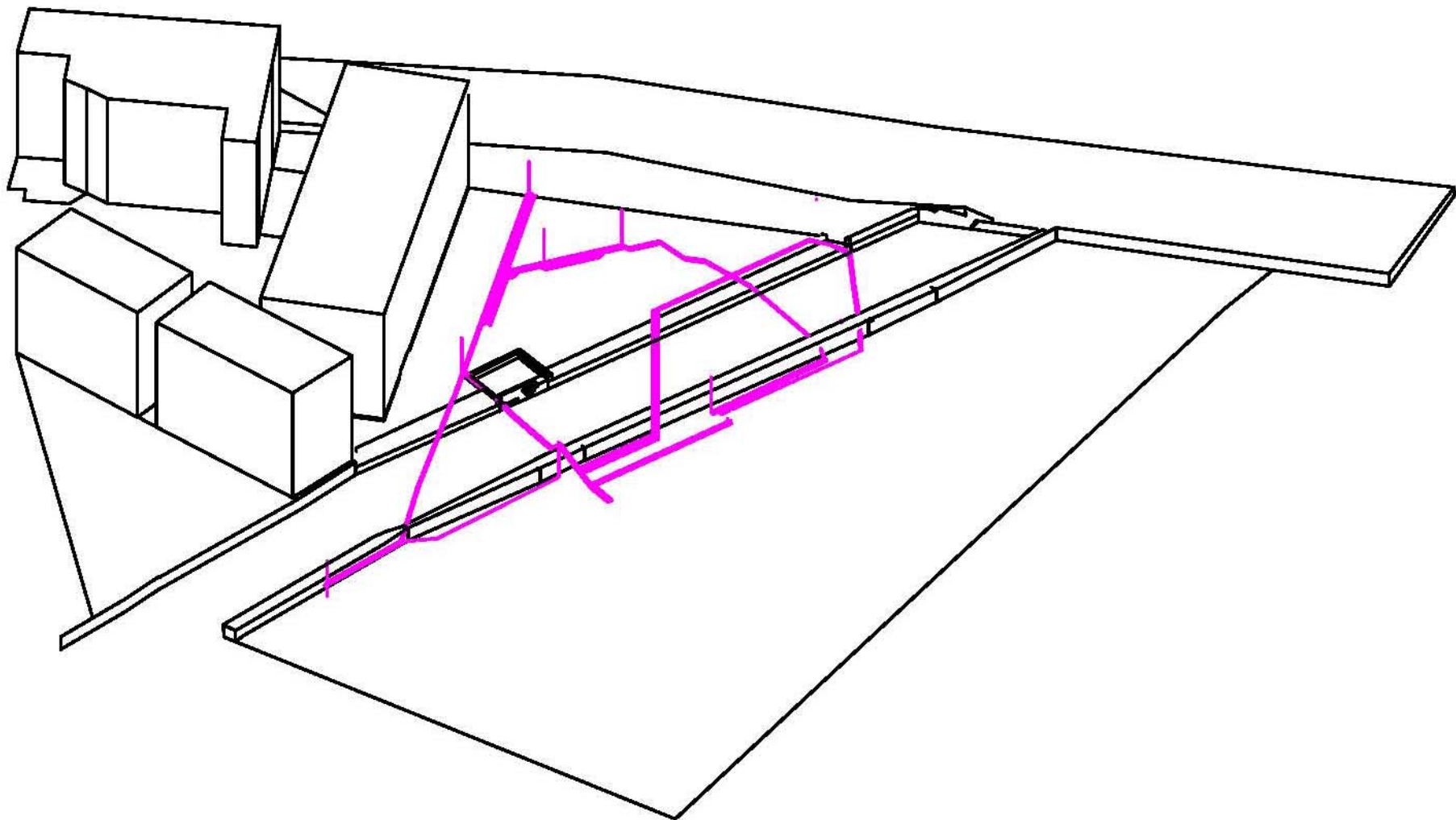

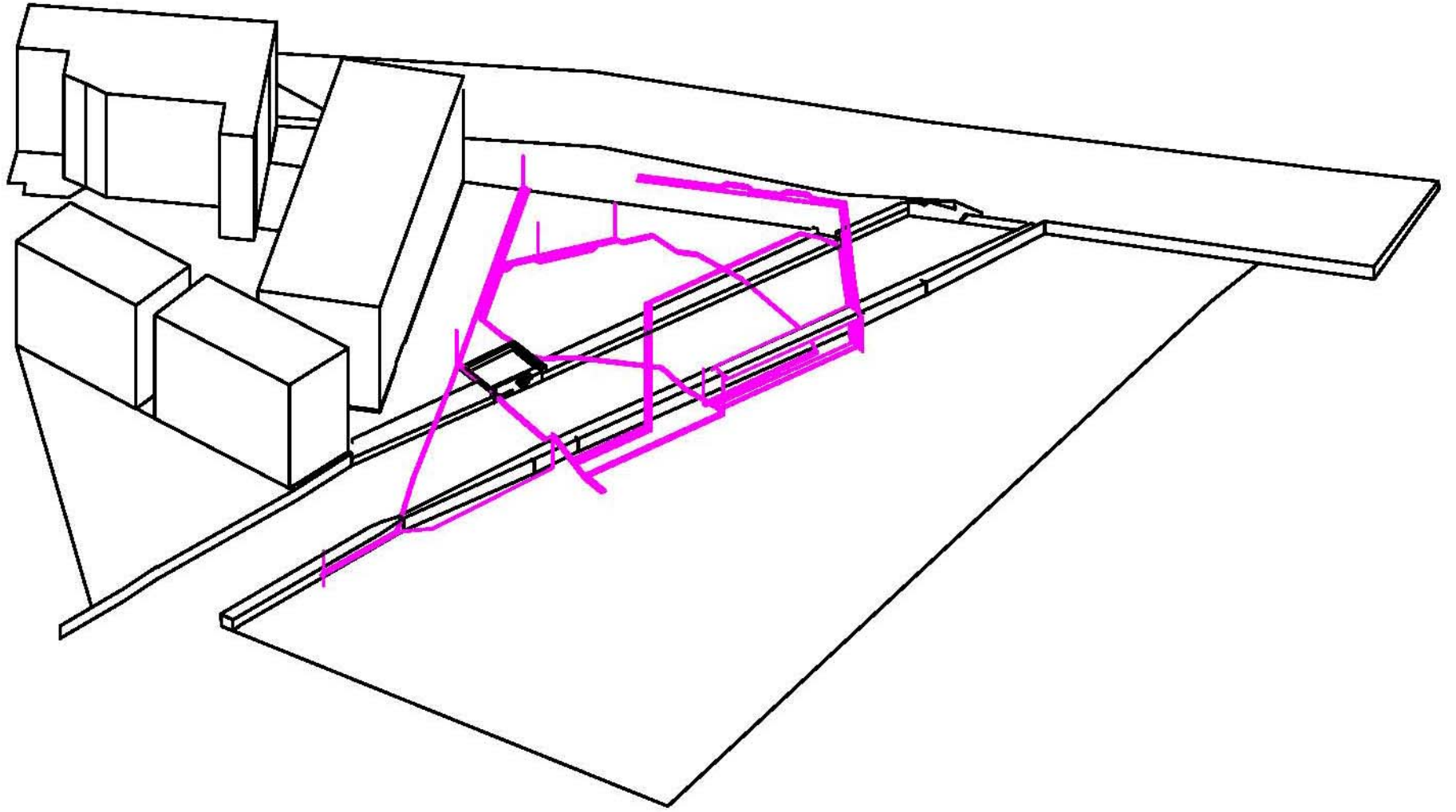

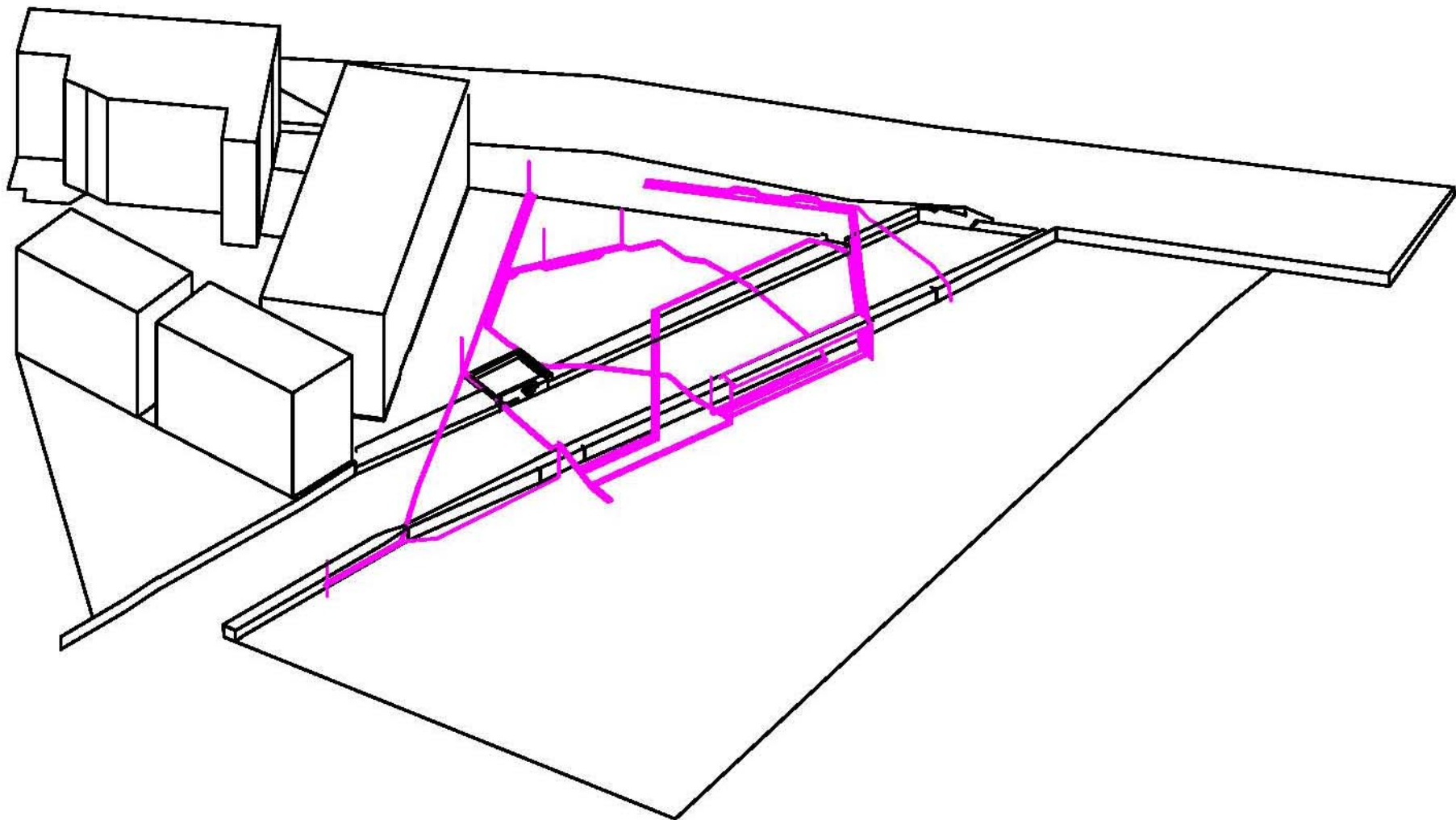

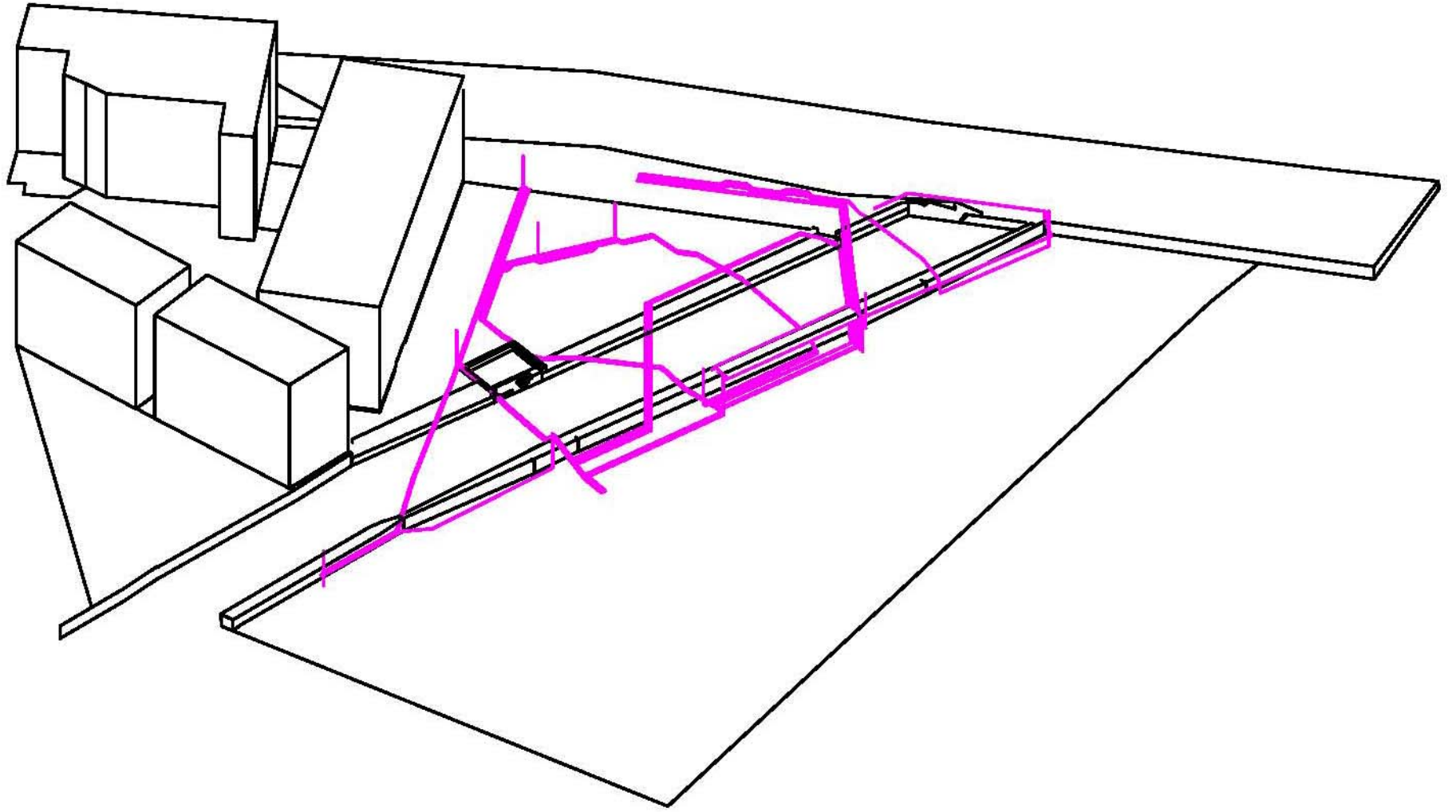

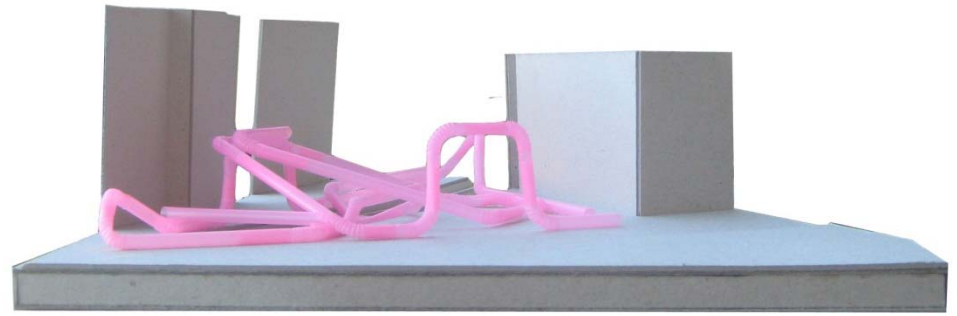
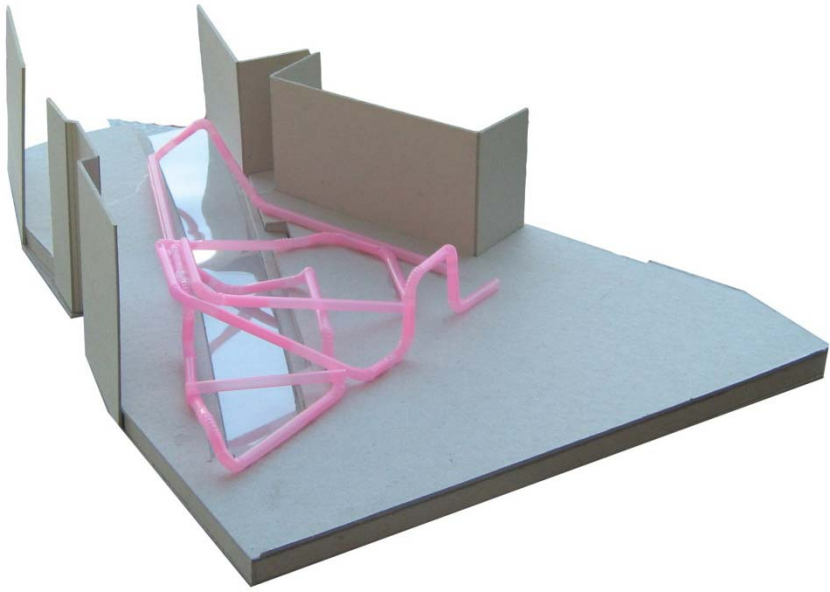

Tlocrt

0 2

5

10



prilaz

P+
5

terase cafe barova

P+
5

Radobolja

druženje i
relaksacija

igra

autobusno
stajalište

prilaz rijeci

čitanje

Bulevar

P+4

Presjeci

0 2

5

10

sheme presjeka

